

PROCENTEC

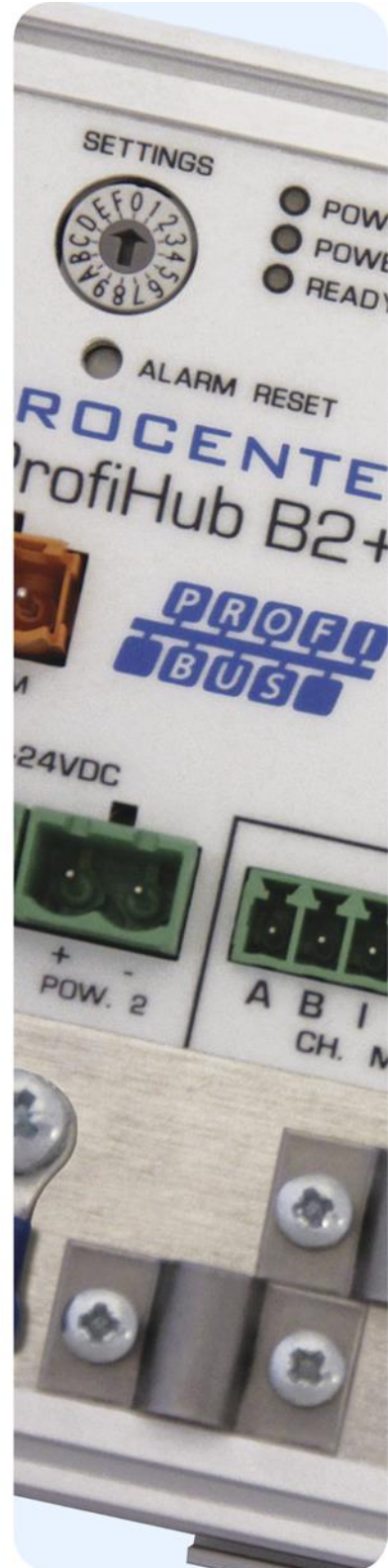
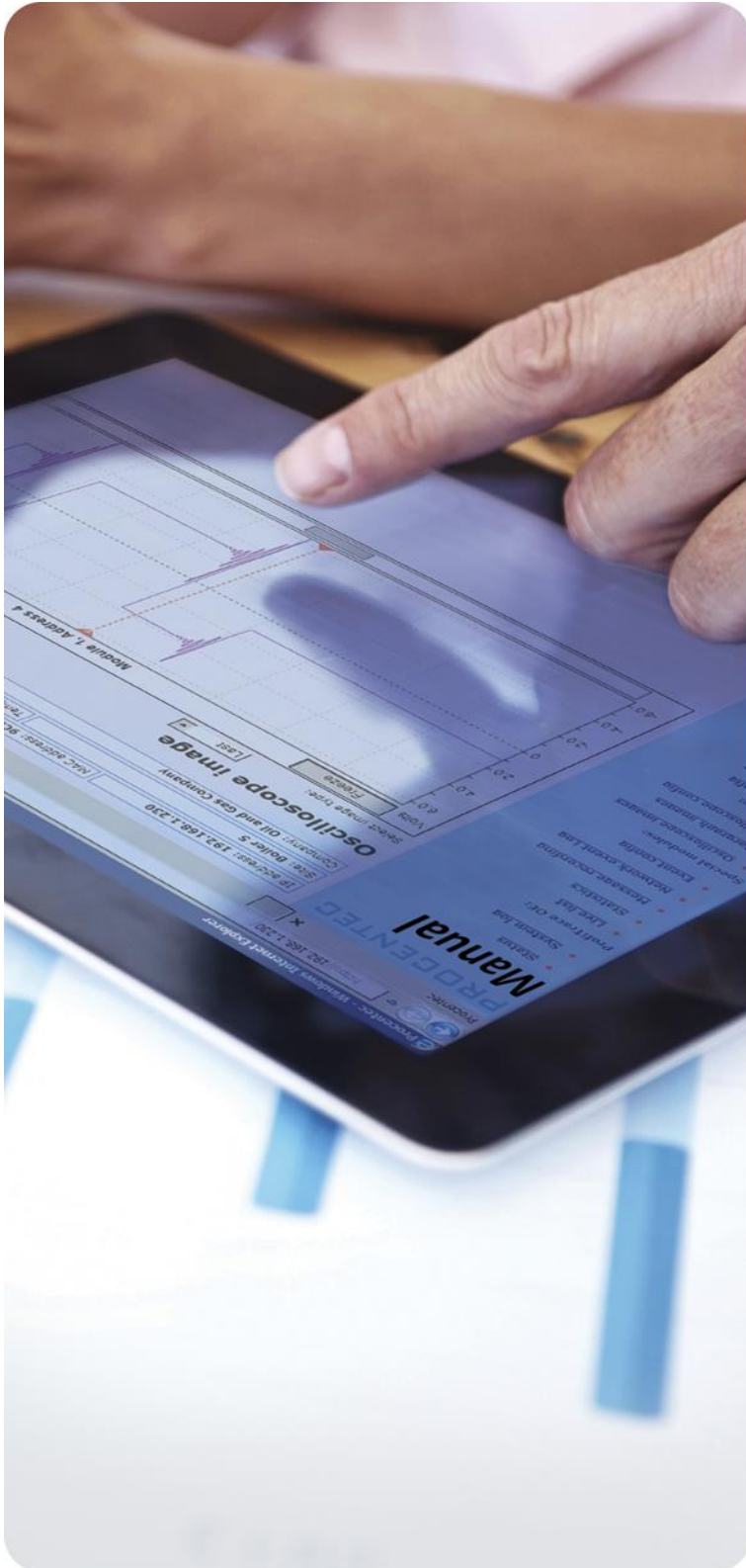

ProfiHub B2+ / B2+RD

2 Channel DP Spur and Repeater component with Redundancy and optional Diagnostics Device

Safety Guidelines

This manual contains notices which you should observe to ensure your own personal safety, as well as to protect the product and connected equipment. These notices are highlighted in the manual by a warning sign and are marked as follows according to the level of danger:

-  Draws your attention to important information on handling the product, a particular part of the documentation or the correct functioning of the product.

Warning

This device and its components may only be used for the applications described in this manual and only in connection with devices or components that comply with PROFIBUS and an RS 485 interface.

This product can only function correctly and safely if it is transported, stored, set up, installed, operated and maintained as recommended.

Qualified Technicians

Only qualified technicians should be allowed to install and work with this equipment. Qualified technicians are defined as persons who are authorized to commission, to ground, to tag circuits and systems in accordance with established safety practices and standards. It is recommended that the technicians carry a Certified PROFIBUS Installer or Certified PROFIBUS Engineer certificate.

Disclaimer of Liability

We have checked the contents of this manual as much as possible. Since deviations cannot be precluded entirely, we cannot guarantee full agreement. However, the content in this manual is reviewed regularly and any necessary corrections included in subsequent editions. Suggestions for improvement are welcomed.

Copyright © 2011-2017 PROCENTEC

All rights reserved. No part of this publication may be reproduced, stored in a retrieval system, or transmitted, in any form or by any means, electronic, mechanical, photocopying, recording or otherwise, without the prior written permission of the publisher

Important information

Purpose of the Manual

This manual explains how to put the ProfiHub B2+ into operation.

Recycling and Disposal

The parts of the ProfiHub can be recycled. For further information about environment-friendly recycling and the procedure for disposing your old equipment, please contact:

PROCEN TEC
Klopperman 16
2292 JD WATERINGEN
The Netherlands

T: +31-(0)174-671800

F: +31-(0)174-671801

E: info@procentec.com

Document Updates

You can obtain constantly updated information on PROCEN TEC products on the Internet at www.procentec.com

You can also contact PROCEN TEC Customer Support:

- by phone at +31-(0)174-671800
- by fax at +31-(0)174-671801
- by email at support@procentec.com

Contents

- Important information 3
- 1. Product Description 6
 - 1.1 Product Features 7
 - 1.2 Application areas 8
 - 1.3 Additional Benefits 8
 - 1.4 Channel Structure 9
 - 1.5 Grounding System 9
 - 1.6 Cable lengths for PROFIBUS DP 10
 - 1.7 Cable types for PROFIBUS DP 11
 - 1.8 Status LEDs 12
- 2. Installation Instructions ProfiHub B2+ 13
 - 2.1 Location 13
 - 2.2 Position 13
 - 2.3 Mounting 13
 - 2.4 Power Supply 14
 - 2.5 Grounding of the power 15
 - 2.6 Relay contact 15
 - 2.7 Backbone 16
 - 2.8 Spur Segments 17
 - 2.9 Termination 18
 - 2.10 Baudrate switch 19
 - 2.11 Channel Redundancy 20
- 3. Diagnostics Device 21
 - 3.1 Setting up the Diagnostics Device 22
 - 3.1.1 Enabling the Diagnostics Device 22
 - 3.1.2 Changing the default PROFIBUS address 22
 - 3.1.3 GSD file 23
 - 3.2 Configuring the Diagnostic Device 23
 - 3.2.1 Info data (mandatory module) 23
 - 3.2.2 Alarm Confirmation 23
 - 3.2.3 Redundant Status 23
 - 3.2.4 Baudrate Status 24
 - 3.2.5 Relay Status 24
 - 3.2.6 Power Status 24
 - 3.2.7 Termination Status 25
 - 3.2.8 Channel Status 25
 - 3.2.9 Livelist Status 25

3.2.10	Statistics (Short Format, Long Format)	26
3.3	Parameterizing the Diagnostic Device	27
3.3.1	Diagnostics.....	27
3.3.2	Statistics.....	28
3.3.3	Extended Diagnostics on Events change	29
3.3.4	Extended Diagnostics on Statistics change.....	30
3.3.5	Alarm Relay on Events change	30
3.3.6	Alarm relay on Statistics change.....	31
3.3.7	Changing the Diagnostics duration/timeout	31
3.3.8	Changing the Device Lost timeout.....	32
3.3.9	Changing the data format.....	32
3.4	ProfiTrace plugin for the Diagnostic Device	33
3.4.1	Installing the Plugin	33
3.4.2	Using the Plugin	33
4.	Technical Data ProfiHub B2+ / B2+RD	35
5.	Sales offices and distributors.....	37
6.	Order codes	42
7.	Glossary	43
8.	Revision History	46
9.	Notes	47
10.	Other PROCENTEC products.....	50
11.	About PROCENTEC.....	51
12.	Certificates.....	52

1. Product Description

ProfiHub B2+ is an advanced, flexible and robust network component for PROFIBUS DP installations, to create backbone structures and long multi-device star/tree segments.

PROFIBUS DP is a high speed communication bus that must comply with strict rules concerning spur lines, because of possible reflections that could lead to communication disturbances. If spur lines or star segments are required, costly investments in repeaters have to be done. When redundancy is enabled, the ProfiHub B2+ is transformed to a low cost extremely reliable redundant repeater solution.

The innovative ProfiHub B2+ is the perfect component for such applications. It is an economic solution to realise reliable spur lines in high speed DP networks. They have the functionality of 2 galvanic isolated transparent repeaters (offering 3 segments). This allows network structures with extended spur lines that individually can handle a maximum of 31 devices and a length equal to the main bus. The ProfiHub B2+ refreshes a received message on one Channel and transfers it to the other Channels (chicken foot topology).

Because the ProfiHub B2+ creates isolated segments, the devices can now be removed and added during operation. Also most electrical bus problems and EMC disturbances in a spur do not spread to the other segments. The intelligent logic and isolation circuits of the ProfiHubs do not change the bit width. This means the ProfiHubs do not have limitations in serial placement. The logic also detects the transmission speed automatically.



Fig. 1 - ProfiHub B2+

To assist the installation work, termination is integrated and can be switched on/off. The grounding concept is also selectable: direct or capacitive grounding. The ProfiHubs are powered by a 12 to 24 DC Voltage. For troubleshooting, maintenance and commissioning the ProfiHubs are equipped with LEDs on the outside, which indicate the status of each Channel (Data and Error).

If bus redundancy is enabled, 2 segments will form a redundant pair which is completely compatible with the ABB RLM01. An alarm contact is linked to events based on the status of the power supply and the bus redundancy status.

1.1 Product Features

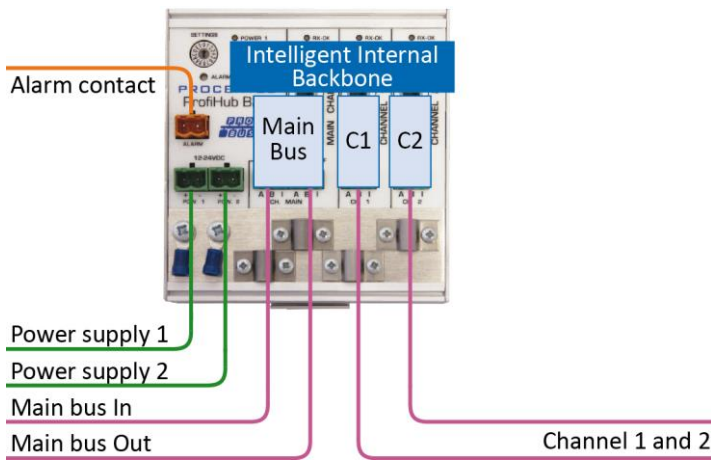

Fig. 2 - ProfiHub connections

- 2 Galvanic isolated outgoing channels (repeater segments)
- Advanced Diagnostic capabilities (B2+RD)
- Transparent for all PROFIBUS DP protocols
- DP - RS 485 specifications for each channel
- Cable redundancy for channel 1+2
- 9.6 Kbps to 12 Mbps
- 31 devices per channel.
- 1200 m spur line length (depends on transmission speed)
- Redundant power supply
- No limit in serial placement or cascading of ProfiHubs
- Alarm contact, with manual reset button
- No address required (except for the B2+RD option)
- Integrated termination facilities (switches)
- Configurable grounding system (direct or capacitive)
- IP 20 classification
- Increased temperature range

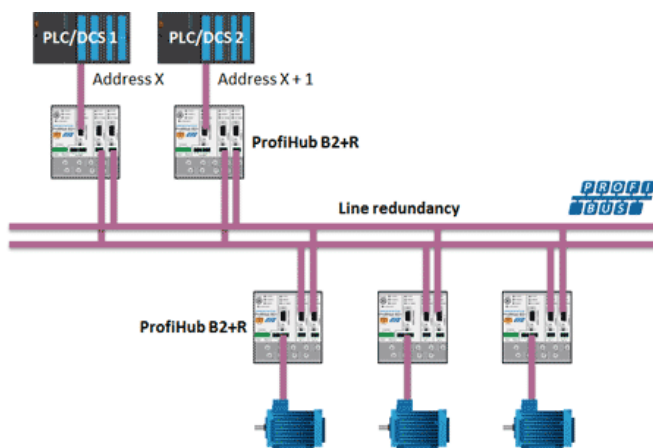

Fig. 3 - If bus redundancy is enabled, 2 segments will form a redundant pair. Short circuit protection on each spur line is automatically provided.

1.2 Application areas

- Dynamic spur lines to actuators, flow meters and pH analyzers
- Removable drives and motors
- Pull/Plug motor control centers (drawers)
- Roof mounted devices in tank farms
- Barrier for non-galvanic isolated equipment
- Networks with requirement for High Availability/uptime
- Large star/tree structured networks

1.3 Additional Benefits

- Create a redundant path to other Hubs or ComBricks
- Hot slave insertion and removal during operation.
- Option to create a redundant path to other Hubs or ComBricks
- Short circuit protection on each Channel
- Compact and robust construction
- Status and error display (per Channel)
- Suitable for all DP cables.
- Conveniently arranged networks
- Easy extendable installations
- On-board DB9 female connector on each channel for maintenance activities
- Cost Savings

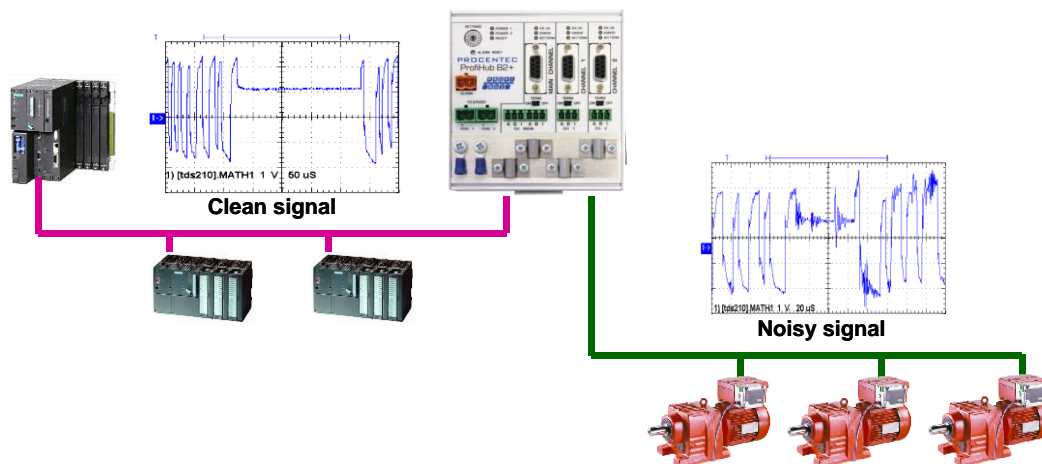

Fig. 4 - Because of the isolation and intelligence the ProfiHub provides, it can be used as a barrier for electrically sensitive segments. This keeps the backbone and other Channels clean.

1.4 Channel Structure

Each Channel is electrically isolated and internally connected to the transparent intelligent backbone. The termination is switchable and powered by the ProfiHub. The shielding of the PROFIBUS cable can be directly grounded or indirectly grounded (see the next paragraph).

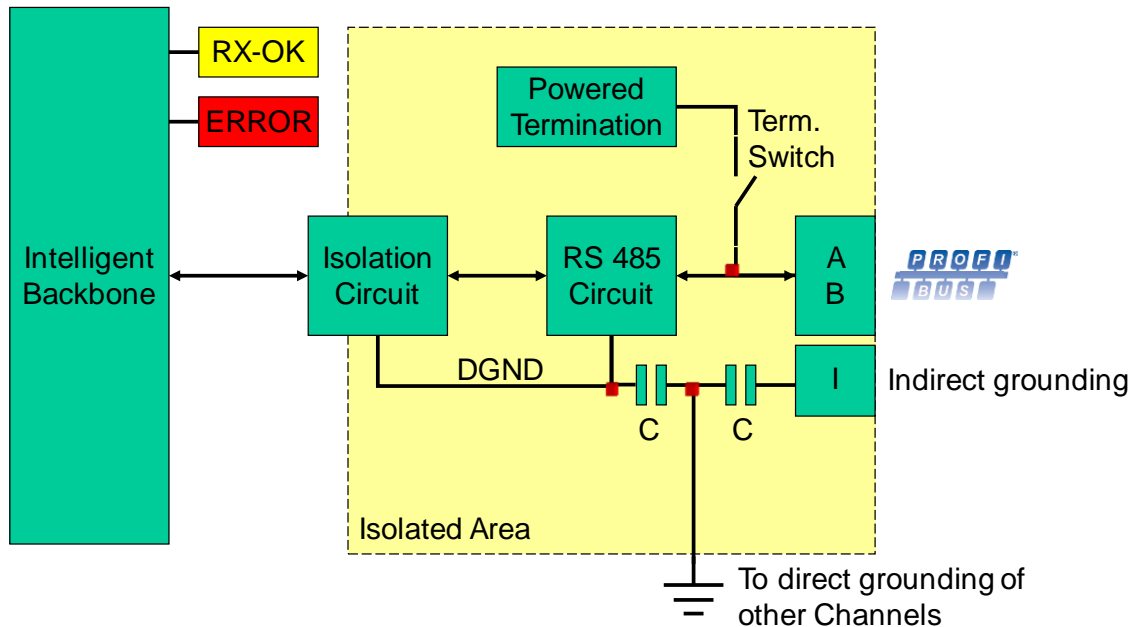

Fig. 5 - Channel structure

1.5 Grounding System

The ProfiHub B2+ can be grounded by 3 methods:

- 1) Direct grounding on the Ground Rail
- 2) Indirect grounding (through a capacitor)
- 3) Combination of direct and indirect.

The power supply must be grounded directly on the Ground Rail. The shielding of the PROFIBUS cables can be directly or indirectly grounded. If you do not want to ground all or some cables to the common ground, i.e. compensating current, the cable shielding must be connected to pin 'I' which stands for Indirect grounding. A capacitor with a parallel high value resistor will separate the 2 potentials (Fig. 5), ensuring protection of the signal against non-DC disturbances.

If by accident on 1 channel the Direct Grounding is connected with the Indirect Grounding, the connection to the Direct Grounding bypasses the capacitor in the Indirect Ground connection. The current on the shield will flow to Direct Ground.

1.6 Cable lengths for PROFIBUS DP

The cables on the Channels and the Main-Channel must comply with the PROFIBUS DP cable specifications for RS 485 (Fig. 6).

Baudrate (kbit/s)	9.6	19.2	45.45	93.75	187.5	500	1500	3000	6000	12000
Segment length (m)	1200	1200	1200	1200	1000	400	200	100	100	100
Segment length (feet)	3940	3940	3940	3940	3280	1310	656	328	328	328

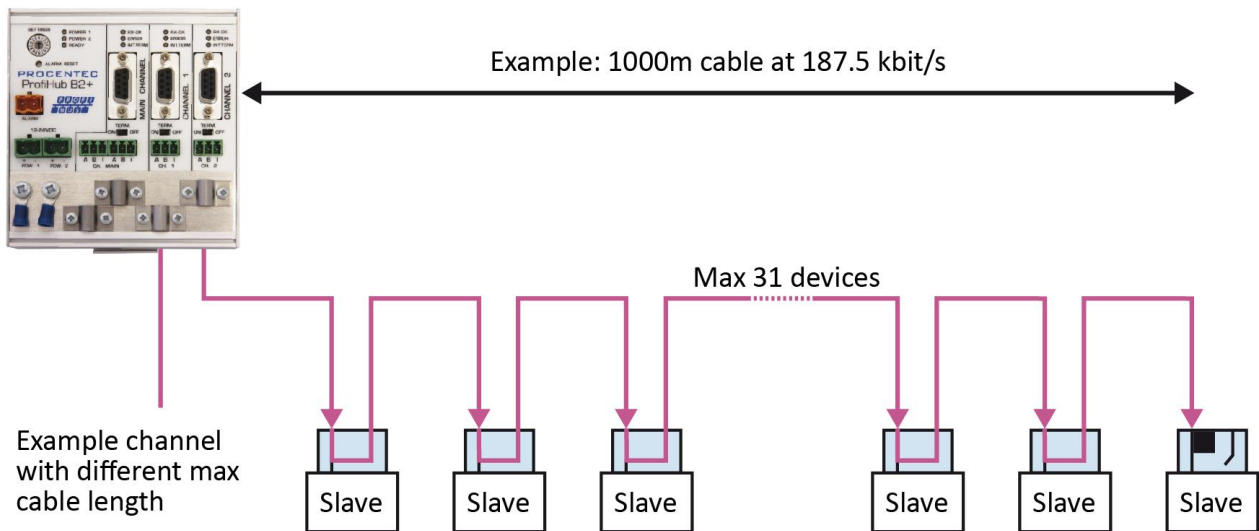

Fig. 6 - Cable lengths for PROFIBUS DP

1.7 Cable types for PROFIBUS DP

The cable type must comply with the PROFIBUS DP cable specifications for RS 485 (Fig. 7).

Parameter	Value
Wires	2 (twisted)
Impedance	135 .. 165 Ohm at 3 to 20 Mhz
Capacity	< 30 pF/m
Loop resistance	< 110 Ohm/km
Wire diameter	> 0.64 mm
Wire area	> 0.32 mm ²

Fig. 7 - PROFIBUS DP cable specifications

The ProfiHub B2+ can handle cables based on multiple protection sheaths with an overall cable diameter between 6 to 12 mm (Fig. 8).

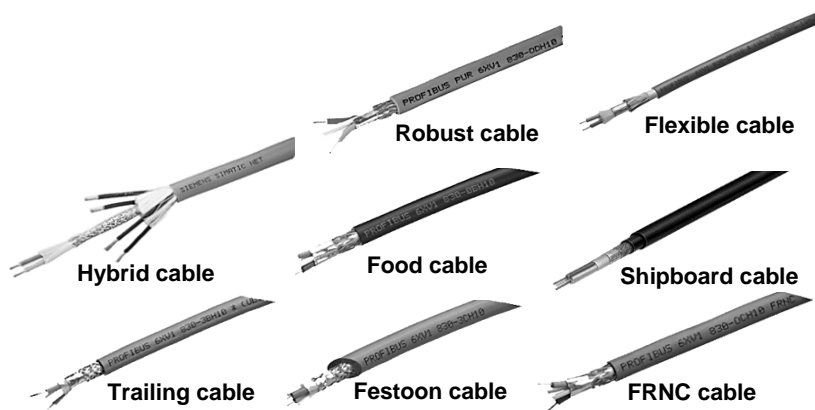

Fig. 8 - Cables with different protection sheaths.

1.8 Status LEDs

The Status LEDs on the ProfiHub are very useful for diagnostics.

	OFF	Blinking	ON
POWER 1 / 2	☹️ Power is not switched on or an internal failure.	⚠️ Power supply not stable, redundant power supply interrupted or an internal failure.	😊 Power supply OK.
READY	☹️ Power is not switched on or an internal failure.	⚠️ Trying to detect the transmission speed, but has not locked it yet.	😊 The transmission speed has been detected.
Main RX-OK	⚠️ No communication detected on the Main-Channel.	😊 1 or more devices communicating on the Main-Channel.	😊 1 or more devices communicating on the Main-Channel.
Main ERROR	😊 No problem has been detected.	⚠️ Problem in the cabling has been detected (Main Channel).	⚠️ Problem in the cabling has been detected (Main Channel).
Channel RX-OK	☹️ There is no communication detected (on this Channel).	😊 1 or more devices communicating (on this Channel).	😊 1 or more devices communicating (on this Channel).
Channel ERROR	😊 No problem has been detected.	⚠️ Problem in the cabling has been detected (on this Channel).	⚠️ Problem in the cabling has been detected (on this Channel).
INT. TERM	Termination for this channel is OFF.	Internal failure.	Termination for this channel is ON.

2. Installation Instructions ProfiHub B2+

2.1 Location

The ProfiHub B2+ can be installed everywhere in a non-hazardous area that complies with IP 20 (DIN 40 050) and the specified temperature range of -25 to +70° Celsius or -13 to +158° Fahrenheit.

2.2 Position

The ProfiHub B2+ can be installed in every position, but it is recommended to install it with the cables pointing down. In this position it is also easier to read the status LEDs.

2.3 Mounting

The ProfiHub B2+ can be mounted on 35 mm DIN-rail with a minimum width of 167 mm. Mounting brackets are available for mounting the B2+ directly on a wall.

The supplied rubber studs need to be placed on the back of the housing of the ProfiHub B2+ for extra fixation. This is to prevent the product to potentially slide off the DIN-rail. See Fig. 9 for an example.



Fig. 9 – Rubber studs on backside of housing

2.4 Power Supply

The two 2-pin screw type power connectors are located on the left of the ProfiHub B2+ (Fig. 10).

1 = + (left)

2 = - (right)

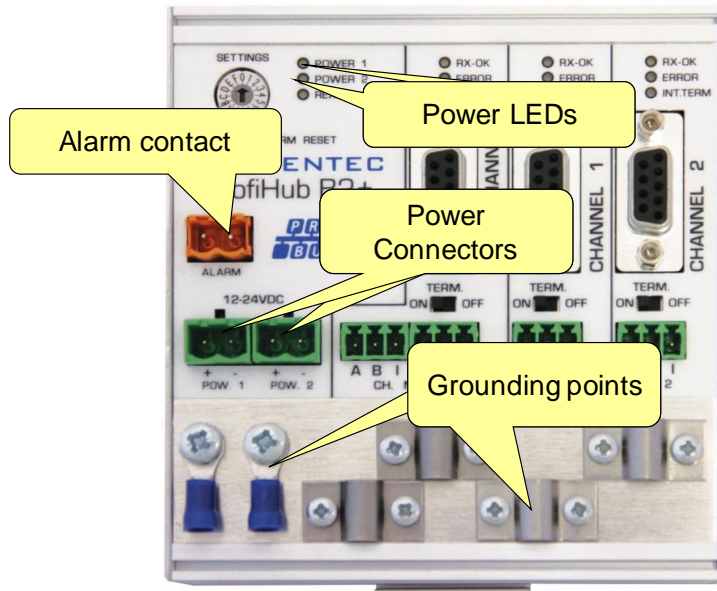

Fig. 10 - Power connectors and LEDs

Both power connectors are linked 1-on-1 to the internal power supply of the B2+. If one power supply fails, the other takes over without delay time. When redundancy is not required, it is sufficient to use one power connector. Please note that when using only one power supply, a voltage of max. 0.25 V will exist on the other unconnected power connector, like shown in Fig. 11.

If only one power supply is used, the alarm contact is closed. If two power sources are connected, the contact is open. As soon as one of the power supplies fails, the contact will close and the Power Indicator LED will blink.

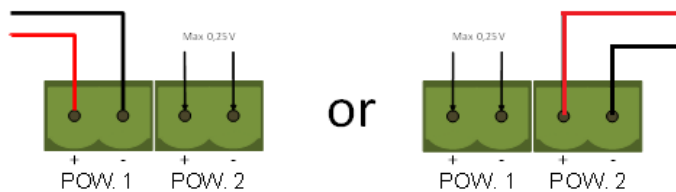

Fig. 11 – Maximum voltage on unconnected Power Connector

Procedure

To connect the 24V supply to the 2-pin screw-type terminal, proceed as follows:

- Strip the insulation from the cable or the conductors for the 24V power supply.
- Add cable crimp terminals/wire ferrules to the conductors.
- Secure the crimp terminals in the screw-type terminal.

To connect the power supply, you need a 3 mm screwdriver.

Testing

If the power is switched on it can be diagnosed by the following indicators:

- LEDs should be blinking in a circular animation for a short time.
- The POWER LED of the respective power connector (1, 2 or both) is ON.
- The READY LED is ON or Blinking, depending on baud rate lock.

2.5 Grounding of the power

① It is recommended to use a power supply with a ground lead (3-wire). Connect the ground lead of the power lead to the Ground Rail of the ProfiHub B2+. Connect the Ground Rail to the common ground with a separate ground lead. See Fig. 12 for an example.

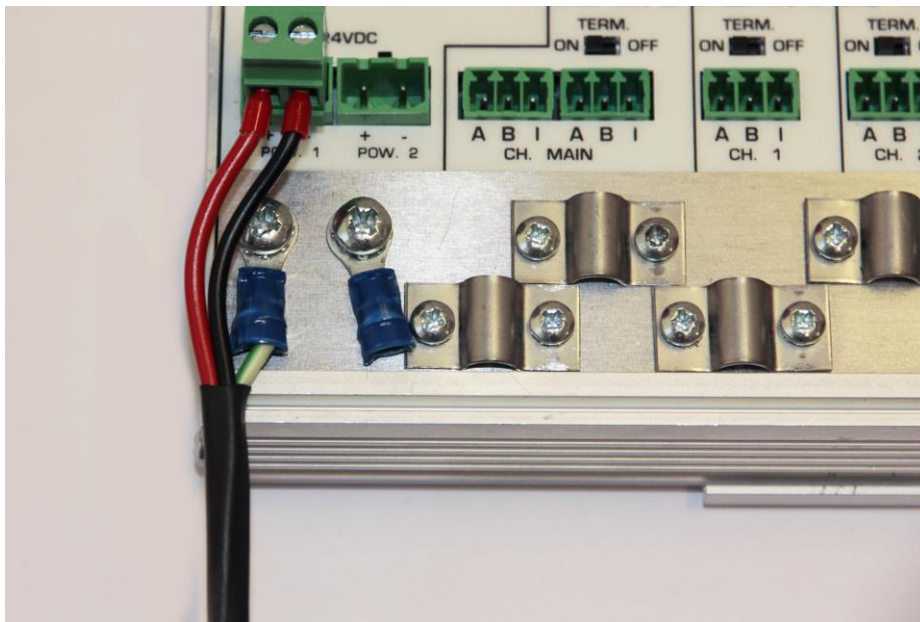

Fig. 12 – Connection to Ground Rail

2.6 Relay contact

The ProfiHub B2+ features a potential-free relay contact. This alarm contact can be used to monitor the power supplies. Example applications are: Connect a LED tower, alarm buzzer, SMS server or use it as a digital signal for the PLC. On the B2+RD version the relay can also be used for alarming in case of retries, illegals, or other events. For more information refer to Chapter 3.

If only one power supply is used, the alarm contact is closed after 60 seconds after start-up. If two power sources are connected, the contact is open. When one of the power supplies fails for 3 seconds or more, the contact will close and the Power Indicator LED will blink. If you are using only one power source and wish to use the Relay contact, simply connect Power 1 to Power 2.

In the case of an interrupted power supply you can reset the contact by pressing the 'Reset' button. The contact will open and the LEDs will stop blinking. The Alarm contact is also switched when the ProfiHub is in Redundant mode and one of the redundant paths fails.

The maximum power to be connected to the alarm contact is 24 VDC. The maximum current consumption is 500 mA.

2.7 Backbone

Connect the DP backbone cable to the bottom-left connector of the Main-Channel (Fig. 13). If the ProfiHub is not the last device on the bus segment, connect the Bus-Out cable to the right connector of the Main-Channel (Fig. 13). The second method is to place a PROFIBUS standardized plug with an in/out cable on the DB9 connector.

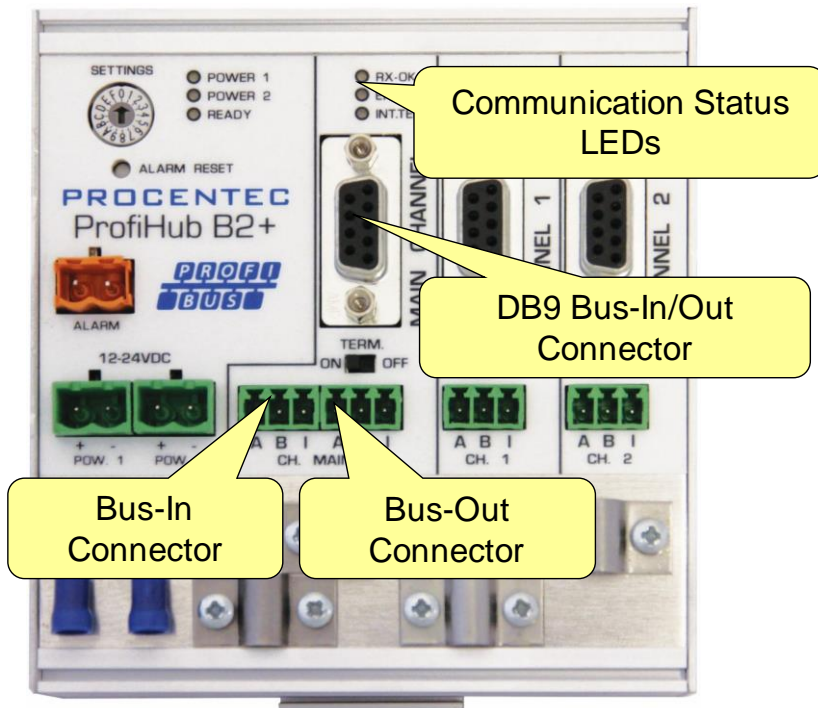

Fig. 13 - PROFIBUS DP backbone connection

Pin layout of the screw terminals:

Pin "A": Green wire

Pin "B": Red wire

Pin "I": Indirect cable shielding

Note: Connecting the Indirect cable shielding is not required when the ground clips are used.

Testing

If the Main-Channel recognizes valid PROFIBUS messages from one or more connected devices, the RX-OK LED of the Main Channel should be blinking.

2.8 Spur Segments

Connect the spur segments to the connectors of Channel 1 to 5 (Fig. 14). The second method is to place a PROFIBUS standardized plug on the DB9 connector of the specific Channel.

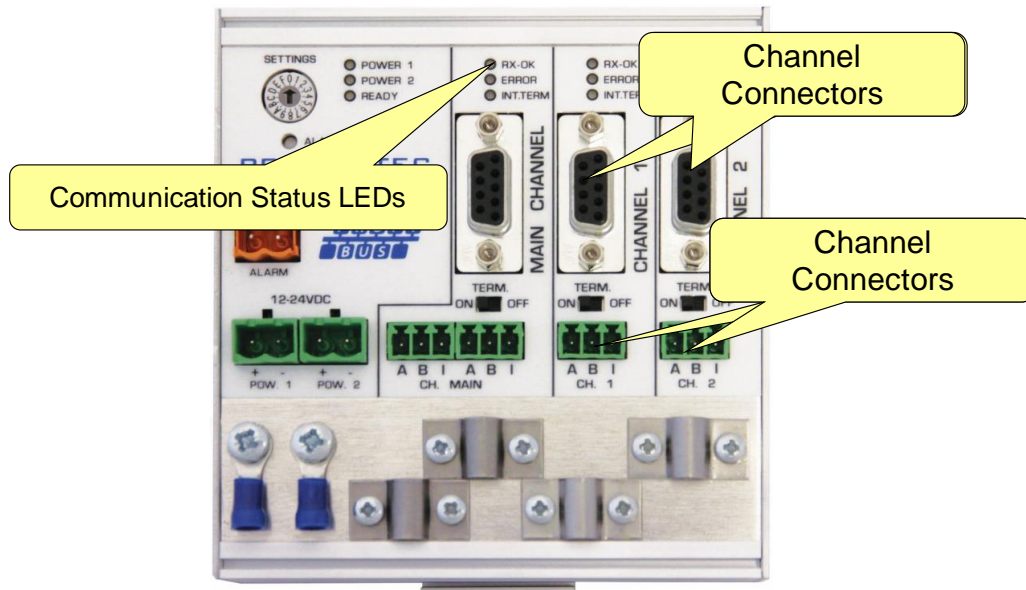

Fig. 14 - PROFIBUS DP spur connectors

Pin layout of the screw terminals:

Pin "A": Green wire

Pin "B": Red wire

Pin "I": Indirect cable shielding

Note: Connecting the Indirect cable shielding is not required when the ground clips are used.

Testing

If a Channel recognizes valid PROFIBUS messages from one or more connected devices, the RX-OK LED of the Channel should be blinking.

2.9 Termination

The termination of the Main-Channel has been set to OFF by default. If the ProfiHub is the last device on the segment, the termination must be set to ON (Fig. 15).

The termination of the Channels have been set to ON by default, because it is assumed that the new segment is started at the ProfiHub (Fig. 15).

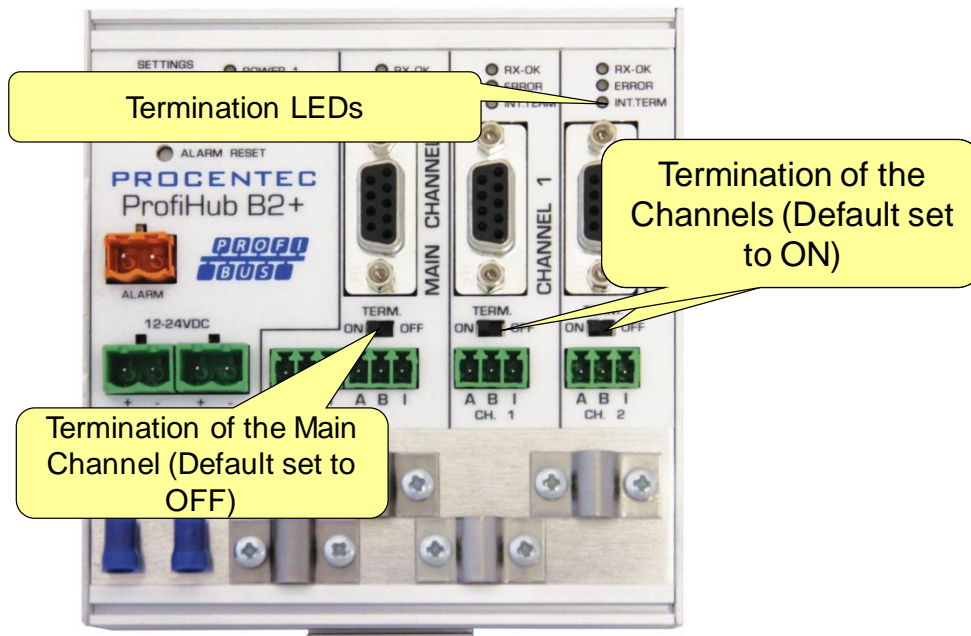

Fig. 15 - Termination Switches

The termination LED of the corresponding Channel is activated when the termination switch is set to ON.

① When the DB9 connector is used and the cable starts at the ProfiHub, it is recommended to use the termination on the DB9 plug and NOT the ProfiHub. This way, the connector can be removed while maintaining termination on the bus.

2.10 Baudrate switch

The ProfiHub B2+ recognizes the transmission speed by default. If it is required that the ProfiHub B2+ is locked to a certain transmission speed, the baudrate switch should be set to the required value (Fig. 16).

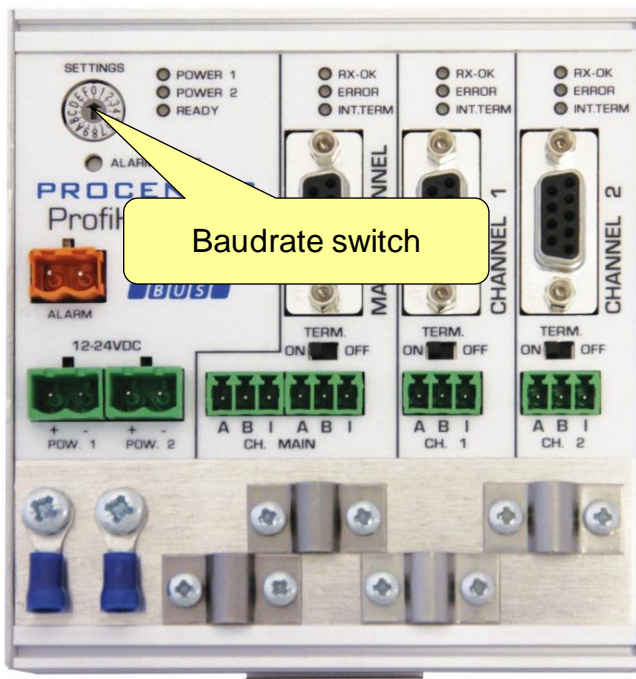

Fig. 16 - Baudrate speed switch

To set the rotary switch, use a 3 mm screwdriver.

Switch values:

- 0 = Normal repeating, Auto baudrate detect (default)
- 1 = fixed 9.6 kbps, diagnostics device ON (B5+RD only)
- 2 = fixed 19.2 kbps, diagnostics device ON (B5+RD only)
- 3 = fixed 45.45 kbps, diagnostics device ON (B5+RD only)
- 4 = fixed 93.75 kbps, diagnostics device ON (B5+RD only)
- 5 = fixed 187.5 kbps, diagnostics device ON (B5+RD only)
- 6 = fixed 500 kbps, diagnostics device ON (B5+RD only)
- 7 = fixed 1500 kbps, diagnostics device ON (B5+RD only)
- 8 = fixed 3000 kbps, diagnostics device ON (B5+RD only)
- 9 = fixed 6000 kbps, diagnostics device ON (B5+RD only)
- A = fixed 12000 kbps, diagnostics device ON (B5+RD only)
- B = Robust repeating, Auto baudrate detect, diagnostics device ON (B5+RD only)
- C = Robust repeating, Auto baudrate detect, redundancy on channel 4 and 5, diagnostics device ON (B5+RD only)
- D = Normal repeating, Auto baudrate detect, diagnostics device ON (B5+RD only)
- E .. F = Reserved for future use

Please note that the position of the rotary switch is only sampled during start-up. Changing the position of the switch will not have effect during operation.

The auto baudrate detect feature will search for the correct baud rate within 10 seconds of receiving the first telegram. This baud rate lock will be lost after 50 seconds of incorrect or no message reception.

In robust repeating mode, only messages starting with a valid PROFIBUS start delimiter are repeated (SD1, SD2, SD3, SD4 and Short Acknowledge). In Normal mode, every bit is transferred immediately onto the other channels.

2.11 Channel Redundancy

To use the Redundancy option of the B2+, set the rotary switch to the 'C' position. This enables the two channels (1 and 2) to be one redundant path to another B2+, to a B5+, a redundant COMbricks or to any other supporting product. See Fig. 17 for an example.

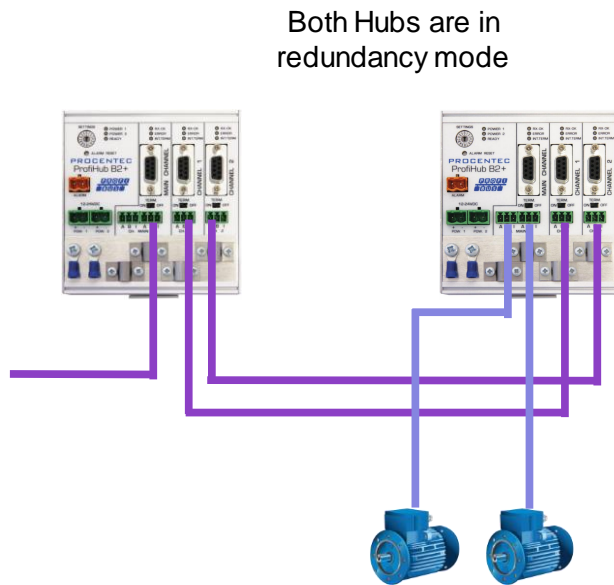

Fig. 17 - Redundant path between two ProfiHubs

The telegrams are transferred onto both redundant channels. The logic inside the ProfiHub determines which telegram is used to be transferred onto the other channels. A message received by a redundant channel is repeated on all other channels, except the other redundant channel. A message received by a normal channel is repeated on all other channels.

When one redundant cable breaks, the other cable ensures safe delivery of the telegram. In this event the built-in alarm contact will close. The red 'ERROR' LED will blink with an interval of 100ms. When the redundant path is fixed, press the 'ALARM RESET' pushbutton to reset the alarm.

ATTENTION:

Using the ProfiHub B2+ in Redundancy mode causes a delay in processing the telegrams. When used together with COMbricks in redundancy mode it is required to increase the default MinTSDR in the PLC busparameters slightly. Recommended is to increase the MinTSDR with a value according to the Delay Time table, column 'Robust Mode', described in the Technical Data chapter.

3. Diagnostics Device

The B2+ is available with a built-in Diagnostics Device option. The order code for this ProfiHub B2 with diagnostics device is 17210RD.

The Diagnostics Device is a very versatile statistics/diagnostics logger. It can be used to keep track of the overall PROFIBUS network health and inform the PLC or DCS of any network failure such as repeats or illegals, missing ProfiHub termination, live list changes, or power supply problems. Audible or visible feedback is also possible by automatically switching the integrated alarm relay.

This information can also be read easily with ProfiTrace because the Diagnostic Device sends this data over PROFIBUS. This enables maintenance engineers to immediately identify the affected segment in case of cable problems or instrument failure. Having a Diagnostics Device in your network dramatically decreases downtime because problems can be solved much quicker; it tells you where to look. SCADA applications can make this even easier.

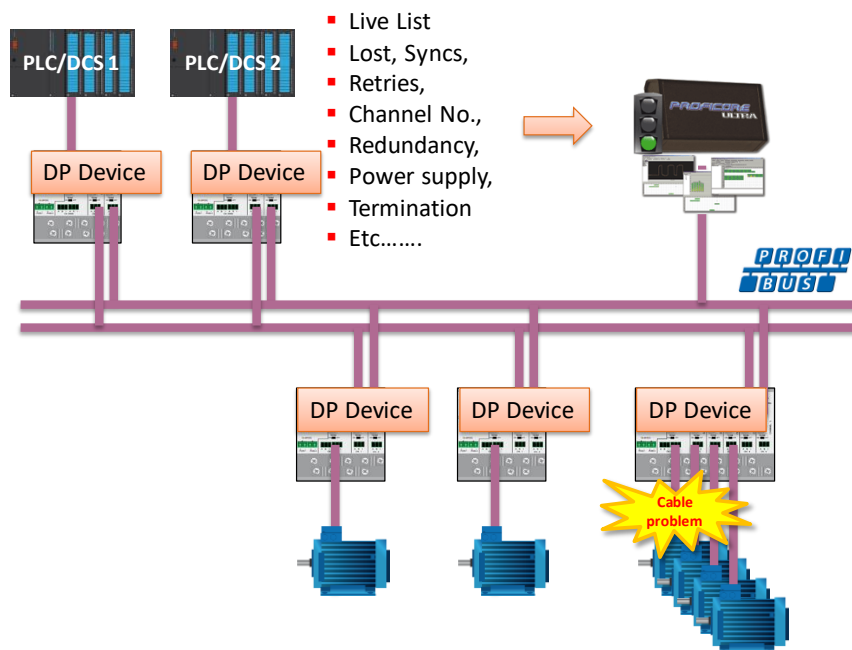

Fig. 18 – Cable problems or node loss can be identified by the ProfiHub channel, and send this information over PROFIBUS to the PLC. ProfiTrace can also read this.

The following statistics and events are continuously monitored:

Events:	Statistics:
Alarm Relay opened/closed	Losses
Cable Redundancy change	Syncs
Baudrate change	Repeats (total)
Power input changed	Repeats (max. changed in 1 cycle)
Termination of Channel changed	Illegals
Communication on Channel stopped/started	Internal Diagnostics
Livelist changed (station removed or added)	External Diagnostics
	Diagnostics while in Data Exchange

All of these events and statistics can be transferred in four different ways, so that the PLC/DCS or user can be warned that something is happening in the PROFIBUS network: a PROFIBUS input message, a diagnostic message, an external diagnostics message, or it can trigger the built-in alarm relay.

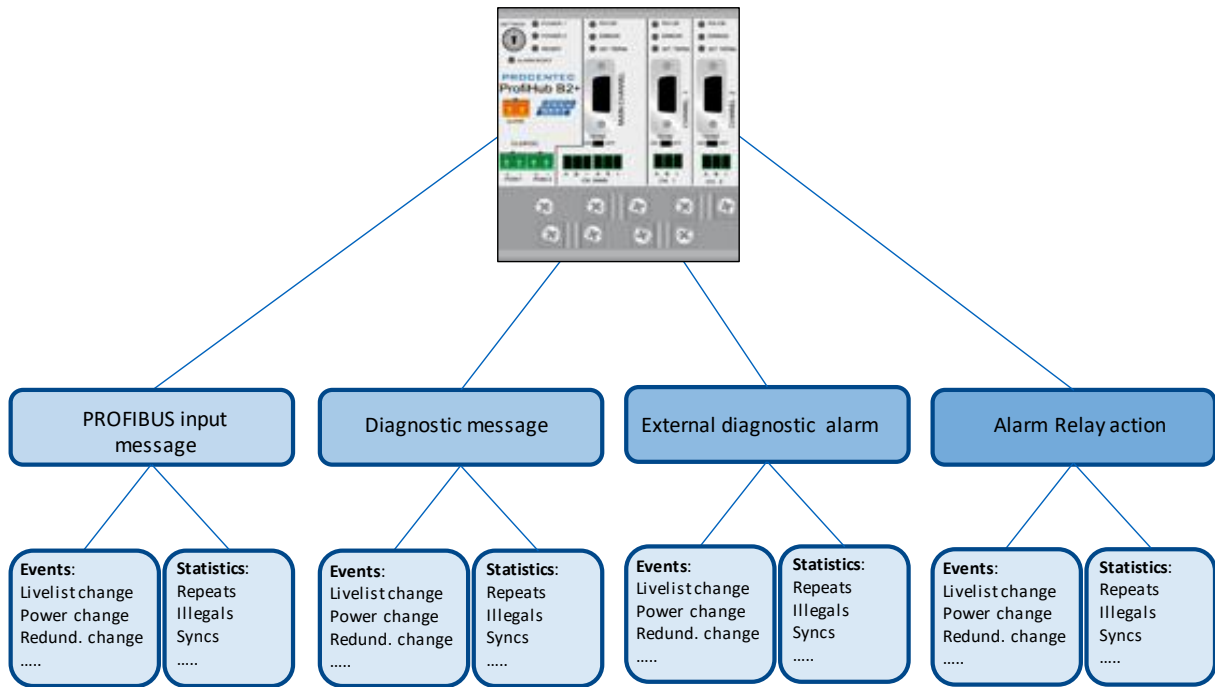

Fig. 19 - Ways of notifying the user in case of problems

3.1 Setting up the Diagnostics Device

3.1.1 Enabling the Diagnostics Device

To enable the Diagnostics Device in the ProfiHub, set the rotary switch on the top left side to any position from 1 to D (for a complete list of rotary switch settings, refer to the Technical Data chapter). Next, power-cycle the device by removing power and applying the power again. The rotary switch position is only read during start-up of the ProfiHub.

3.1.2 Changing the default PROFIBUS address

By default the address of the Diagnostic Device is set to 126. To change the address, use a configuration tool which supports the 'Set Slave Address' command. Most configuration tools support this feature.

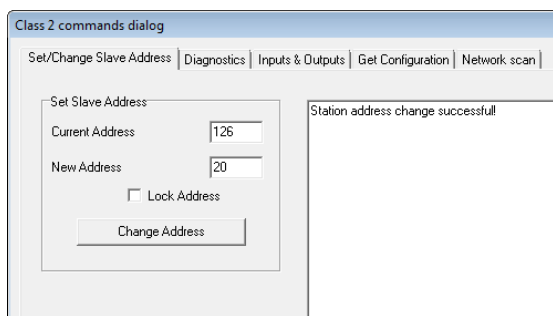

Fig. 20 - ProfiCaptain changes the address from 126 to 20

3.1.3 GSD file

Locate and download the appropriate GSD file for the Diagnostics Device on www.procentec.com/downloads. The correct GSD file for the ProfiHub B2+RD is: PROC6971.gsd The zip file also contains the corresponding .bmp (Bitmap) files. Import the GSD file into your configuration tool and insert the device in the PLC hardware configuration.

3.2 Configuring the Diagnostic Device

The Diagnostic Device has many configuration options. It can be configured modularly. This paragraph describes all the available options per module in list order.

3.2.1 Info data (mandatory module)

There is only one mandatory module, which is the first module in the list (“INFO DATA MANDATORY ON 1st SLOT”). It has 4 input bytes with the following meaning:

- Byte 1: Input Identifier byte (always 0xDE)
- Byte 2: Device type byte (0xB5 is ProfiHub B5+, 0xB2 is ProfiHub B2+)
- Byte 3: Version byte: 0x01
- Byte 4: Data format byte (0x00 is Little Endian, 0x01 is Big Endian)

3.2.2 Alarm Confirmation

Input Identifier byte: 0x01

The Alarm Confirmation module has one Output, which can be used to reset the alarm. If the Alarm Relay has been triggered by any event (see paragraph **Fout! Verwijzingsbron niet gevonden.**), it can be reset by the PLC by sending 0x01 or higher to the output of this module.

3.2.3 Redundant Status

Input Identifier byte: 0x10

The next input byte is to indicate the status of the redundant path. It is divided in nibble 0..3 and 4..7.

Nibble 1 (0..3)	Meaning
1 dec	Redundancy not used
2 dec	Redundancy error left channel
3 dec	Redundancy error right channel
4 dec	Redundancy error both channels
5 dec	Redundancy OK
Nibble 2 (4..7)	
1 dec	Pending Alarm: Redundancy error left channel
2 dec	Pending Alarm: Redundancy error right channel
3 dec	Pending Alarm: Redundancy error both channels

Examples: 0x12 means Redundancy error on Left Channel, Pending alarm on Left Channel
0x05 means Redundancy OK

3.2.4 Baudrate Status

Input Identifier byte: 0x11

The next input byte is to indicate the baudrate lock status.

Dec	Meaning
1	No baudrate detected
2	9.6 Kbit
3	19.2 Kbit
4	45.45 Kbit
5	93.75 Kbit
6	187.5 Kbit
7	500 Kbit
8	1.5 Mbit
9	3 Mbit
10	6 Mbit
11	12 Mbit

3.2.5 Relay Status

Input Identifier byte: 0x12

The next input byte is to indicate the alarm relay status.

Hex	Meaning
00	Relay is off
01	Relay is on

3.2.6 Power Status

Input Identifier byte: 0x13

The next input byte is to indicate the status of the power inputs.

Nibble 1 (bit 0..3)	Meaning
0	Power 1 is active
1	Power 2 is active
Nibble 2 (bit 4..7)	
4	Pending Alarm: Power 1 not active
5	Pending Alarm: Power 2 not active

Examples: 0x03: Power 1 and 2 are active
0x21: Power 1 is active, pending alarm: Power 2 not active
0x32: Power 2 is active, pending alarm: Power 1 and 2 not active (Relay should be reset in this case)

3.2.7 Termination Status

Input Identifier byte: 0x14

The next input byte is to indicate the status of the termination switches on the ProfiHub channels.

Bit	Meaning
0	Main Channel termination ON
1	Channel 1 termination ON
2	Channel 2 termination ON

Examples: 0x07 = All terminations are ON
0x01 = Only Main Channel termination is ON

3.2.8 Channel Status

Input Identifier byte: 0x15

The next input byte is to indicate the communication status of the individual channels.

Bit	Meaning
0	Communication on Main Channel
1	Communication on Channel 1
2	Communication on Channel 2

Examples: 0x06 = Communication on Channels 1 and 2
0x01 = Communication on Main Channel

3.2.9 Livelist Status

Input Identifier byte: 0x20

The next input byte is to indicate which Channel is selected to display the Livelist status.

Hex	Meaning
80	Livelist of Main Channel
81	Livelist of Channel 1
82	Livelist of Channel 2
86	Livelist of this ProfiHub
FF	Livelist of all channels (entire network)

The next 32 input bytes are used for the actual Livelist data. Each address uses two bits. So the first two bits of the first byte are for address 0, the next two bits of the first byte are for address 1 and so on. The bits are used to indicate if the station is a slave device, master device or both.

Device:	Bit 1:	Bit 0:
None	0	0
Slave Device	0	1
Controller	1	0
Both	1	1

Example: If there is a master device on address 2, and a slave device on address 3, then the first byte will be 0x60, because it will look like this:

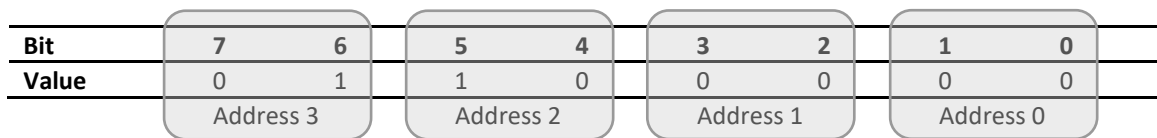

This module also has 2 Output bytes. The first Output byte is used to select the Livelist of a specific Channel. This selection can be read-back in the Input byte described above.

Hex	Meaning
80	Livelist of Main Channel
81	Livelist of Channel 1
82	Livelist of Channel 2
86	Livelist of this ProfiHub
FF	Livelist of all channels (entire network)

The next Output byte can be used to reset the Livelist. Write 0x01 to this Output byte to reset the Livelist.

3.2.10 Statistics (Short Format, Long Format)

Input Identifier byte: 0x30 (short format) or 0x31 (Long Format)

The next byte is used to display the current selection of statistics that it sends.

Hex	Meaning
00..7E	Statistics for device 0..126
7F	Statistics for undefined devices
80	Statistics of Main Channel
81	Statistics of Channel 1
82	Statistics of Channel 2
86	Statistics of this ProfiHub
FF	Statistics of all channels (entire network)

The next 16 bytes (Short Format) or 32 bytes (Long Format) are used to transfer the statistics of the selected address, selected Channel or all Channels of the ProfiHub. Each statistic uses 2 bytes (Short Format, so a maximum of 65535 decimal per statistic) or 4 bytes (Long Format) and is sent in the following order:

1. Lost count
2. Sync count
3. Repeats total count
4. Repeats max per cycle count
5. Illegals count
6. Int. diagnostics count
7. Ext. diagnostics count
8. Diagnostics while in Data Exchange count

This module also has 2 output bytes. The first byte is used to configure the ProfiHub Statistics; you can choose which stations or Channels will display statistics. Configure it by sending the following output value:

Hex	Meaning
00..7E	Statistics for device 0..126
7F	Statistics for undefined devices
80	Statistics of Main Channel
81	Statistics of Channel 1
82	Statistics of Channel 2
86	Statistics of this ProfiHub
FF	Statistics of all channels (entire network)

The next output byte can be used for clearing the statistics. Please note that the selected statistics of ALL node addresses and/or ProfiHub channels are cleared, not only for the displayed address or channel.

Bit	Meaning
0	Clear LOST statistics
1	Clear SYNC statistics
2	Clear REPEATS TOTAL statistics
3	Clear REPEATS MAX statistics
4	Clear ILLEGALS statistics
5	Clear INT. DIAG statistics
6	Clear EXT. DIAG statistics
7	Clear DIAG WHILE IN DX statistics

Example: To clear all LOST and ILLEGALS statistics, send 0x11
 To clear all statistics, send 0xFF

3.3 Parameterizing the Diagnostic Device

The Diagnostic Device has many user-definable parameters that can be changed, to alter the behaviour and options of the ProfiHub Diagnostics Device.

3.3.1 Diagnostics

The Diagnostics Device sends a diagnostic message on PROFIBUS whenever certain conditions are changed. These changes can be any of the following:

- Livelist change (a station added or removed)
- Bitrate error
- Alarm relay active
- Power status changed (one of the two power sources added or removed)
- Redundancy status change (one of the redundant cables added or removed)
- Termination status change (a termination switch on the ProfiHub has been changed)
- Channel status change (communication stopped or started on a channel)
- Statistics change (any statistic has changed)

In your configuration tool you can toggle the diagnostics for each item.

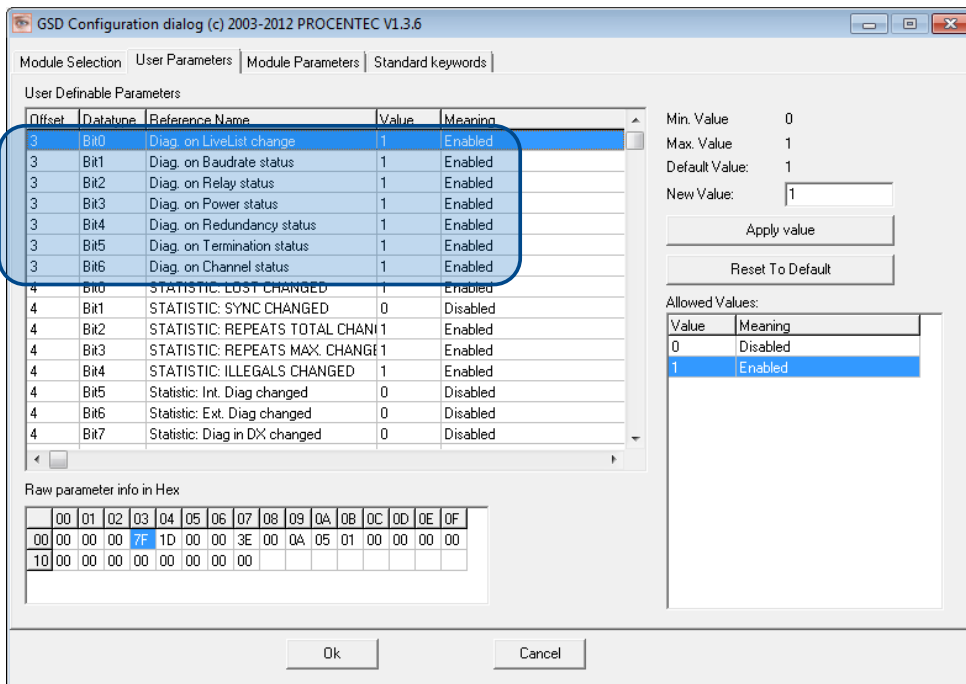

Fig. 21 - Screenshot of ProfiCaptain - User Parameter window

The 8th byte of a diagnostic message from the Diagnostic Device indicates which options have been enabled or disabled.

3.3.2 Statistics

You can choose which Statistics can trigger a diagnostic message, because not all statistics are interesting in all networks. For example, Syncs have been disabled by default because this is not a statistic that is suitable for PROFIBUS health monitoring.

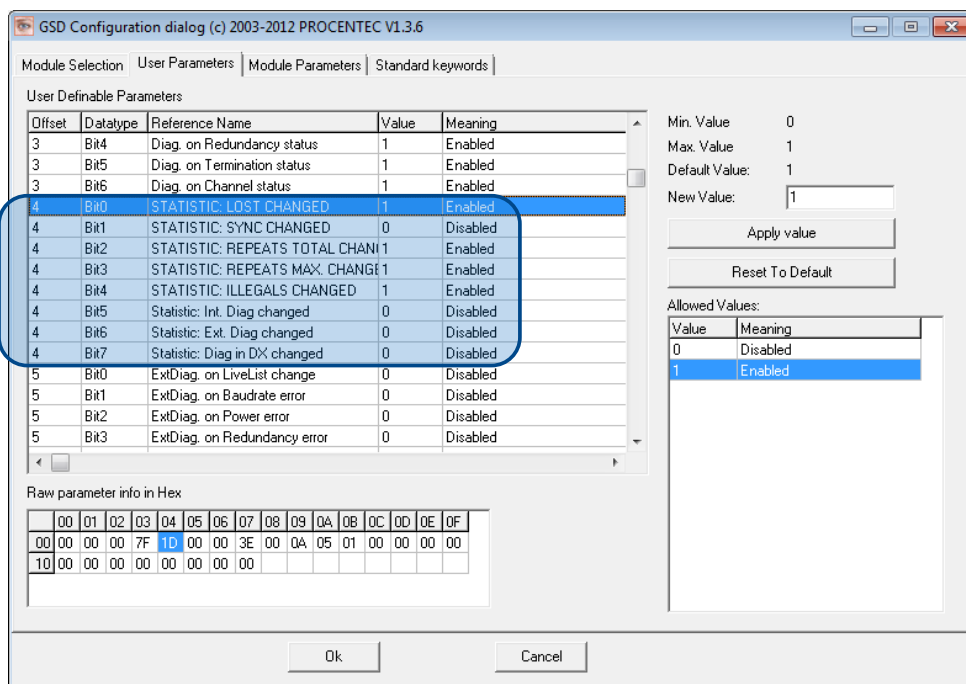

Fig. 22 – You can choose which statistics trigger a diagnostic message

The following Statistics can trigger a diagnostic message of the Diagnostic Device:

- Lost changed
- Sync changed
- Repeats (total) changed
- Repeats (max) changed
- Illegals changed
- Internal Diagnostics changed
- External Diagnostics changed
- Diagnostics in Data Exchange changed

3.3.3 Extended Diagnostics on Events change

For more critical applications you can choose to enable the ‘Extended Diagnostics’ option for each of the previously mentioned events. In the case of such an event, the Diagnostics Device will send out a diagnostics message with the ‘Extended Diagnostic’ bit on. In a Busmonitor tool such as ProfiTrace the extended diagnostics bit will appear as a red blinking square.

40	41
ProfiHub-B5+ Diagnostics	51
60	61

All Events described in paragraph 3.3.1 can trigger the Extended Diagnostic bit of the Diagnostic Device. By default, the Extended Diagnostic option is disabled. Each item can be enabled individually.

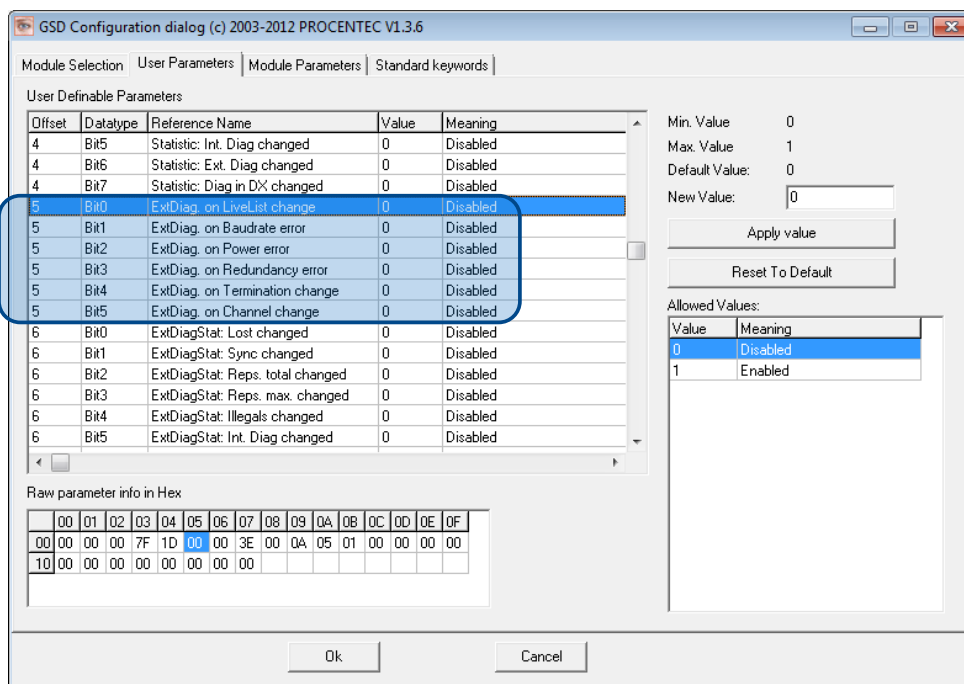

3.3.4 Extended Diagnostics on Statistics change

The Extended Diagnostic option can also be enabled for each individual available statistic. This works the same way as the Events described in paragraph 3.3.3.

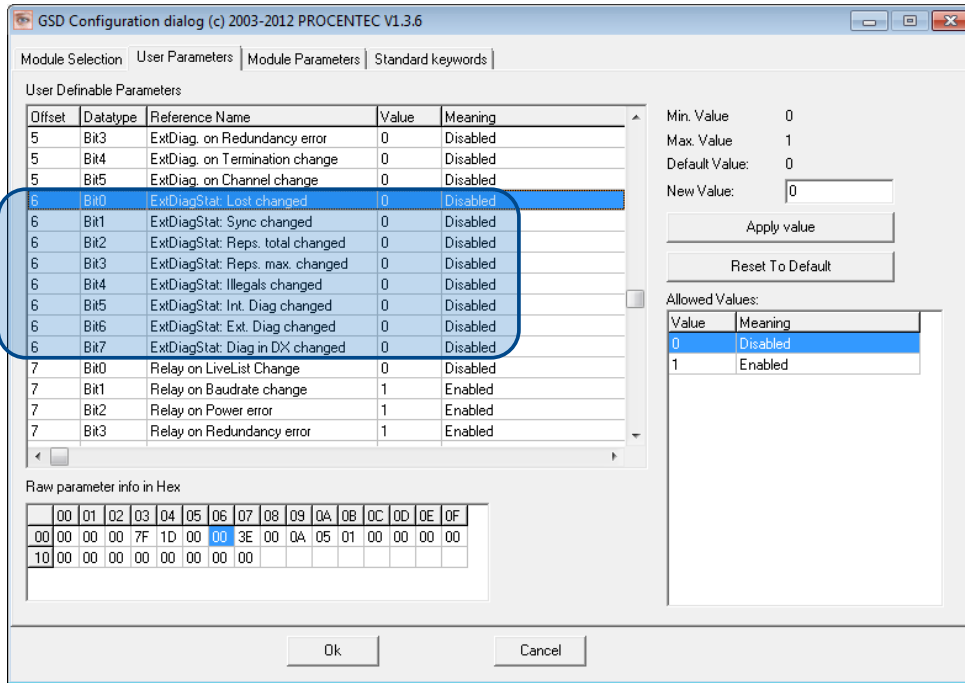

3.3.5 Alarm Relay on Events change

The Alarm Relay on the ProfiHub can be switched on each Event described in paragraph 3.3.1. When such an Event occurs, the Relay will be switched immediately without delay. The only Event that can delay the switching of the Alarm Relay is the Lost event. See paragraph 0 for an explanation.

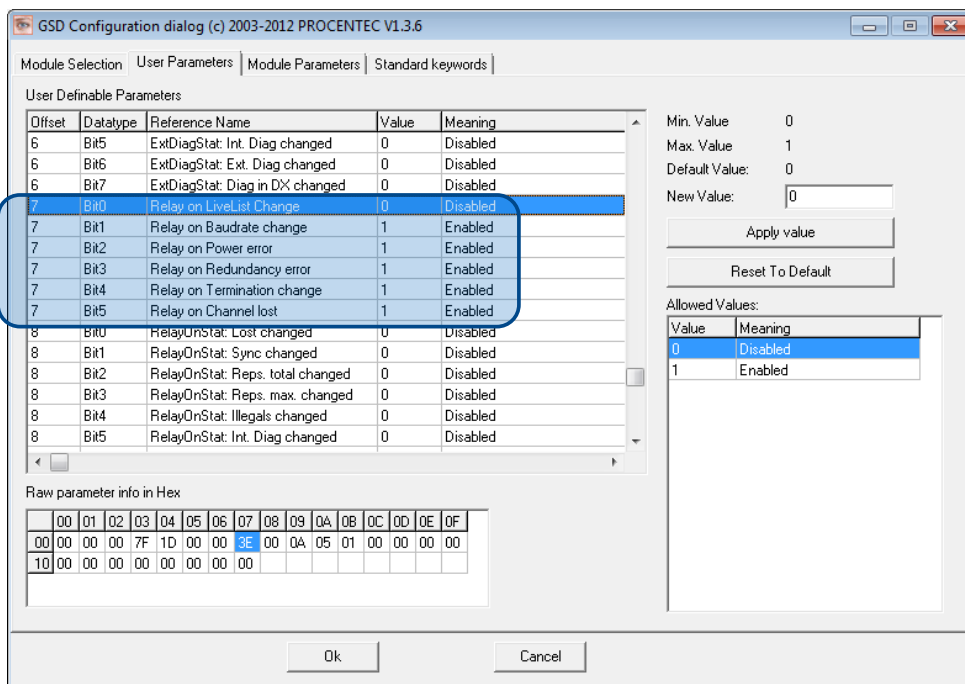

3.3.6 Alarm relay on Statistics change

The Alarm Relay on the ProfiHub can be switched (closed) on each change in Statistics, described in paragraph 3.3.2. When such an (enabled) Statistic change occurs, the Relay will be switched immediately without delay. The only Statistic that can delay the closing of the Alarm Relay is the Lost event. See paragraph 0 for an explanation.

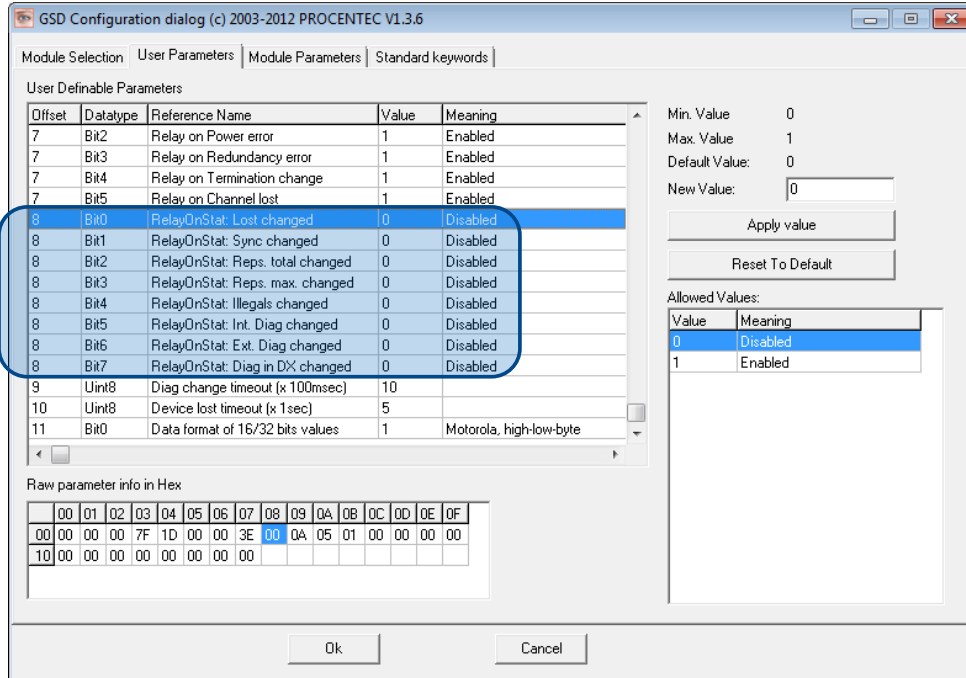

3.3.7 Changing the Diagnostics duration/timeout

You can change the duration of the Extended Diagnostics warning in steps of 100 milliseconds. The default value is 10, so 1 second. The maximum value is 255.

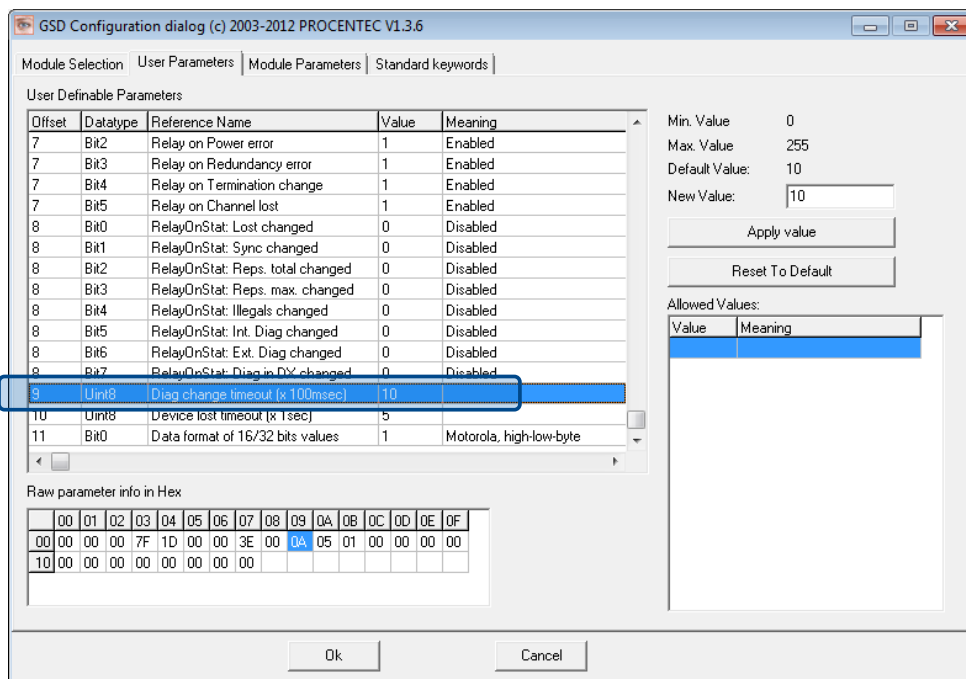

3.3.8 Changing the Device Lost timeout

The Diagnostics Device waits for a certain time before it considers a slave to be lost. This works in a similar way as the ProfiTrace Live List, where the background turns yellow when a slave stops communicating. This timeout can be changed in steps of 1 second. Default value is 5, and maximum value is 255.

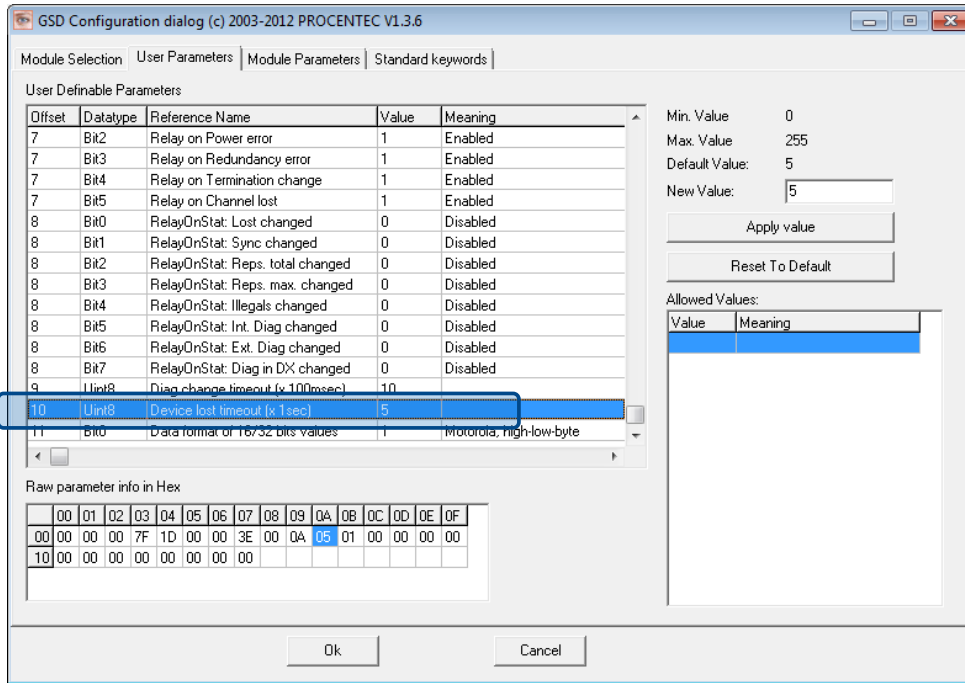

3.3.9 Changing the data format

The data format can be changed if needed. Default is Motorola, high-low-byte format. You can change it to Intel, low-high-byte format.

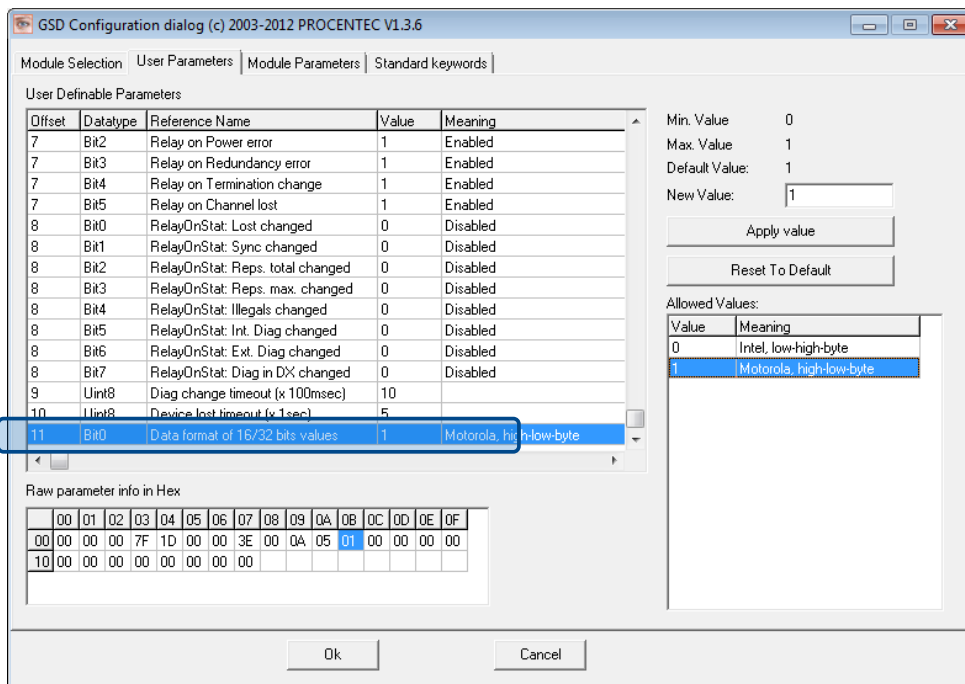

3.4 ProfiTrace plugin for the Diagnostic Device

On the download section of www.procentec.com you can download a useful plugin for the Diagnostic Device. It interprets all messages to and from the Diagnostic Device and displays the data in the Info Panel of ProfiTrace.

3.4.1 Installing the Plugin

Once you have downloaded the file and extracted it to your hard drive, start ProfiTrace and choose 'Settings – Plugins' to bring up the Plugin window.

Click 'Install Plugin' and locate it on your harddrive.

Next, click 'Enabled' so that ProfiTrace starts the plugin on startup.

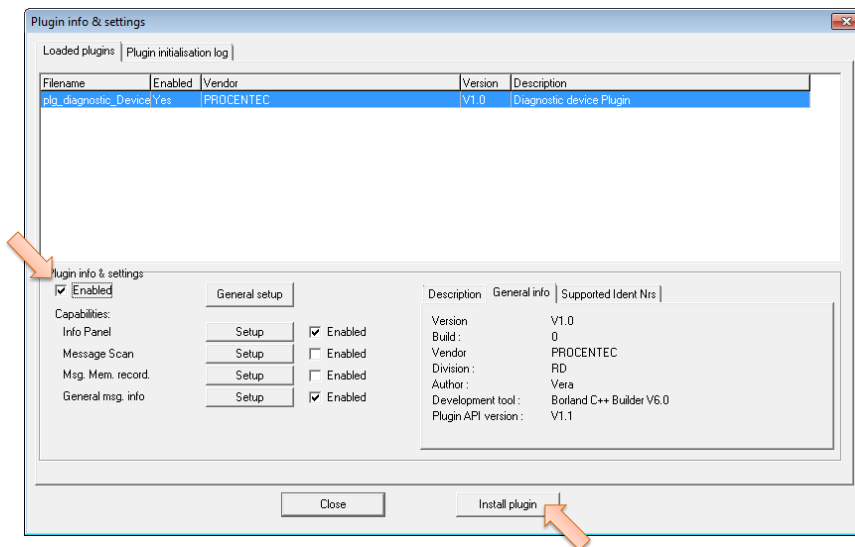

3.4.2 Using the Plugin

When the Plugin is correctly started and you have a ProfiHub with Diagnostics Device running, click 'Start Message Recording' in ProfiTrace, and view the screen with messages (see Fig. 23). If you click on a data exchange message to or from a Diagnostics Device, you will see all the interpreted data bytes in the Info Panel. This is very useful for Troubleshooting activities.

A good example is the Statistics. These statistics are available per individual channel or station address (see paragraph 3.2.10), so it is easy to see the source of the problem.

4. Technical Data ProfiHub B2+ / B2+RD

Technical Data ProfiHub B2+																						
Dimensions and weight Dimensions L x H x D (mm) with screws Weight	102 x 111 x 32 mm Approximately 320 g																					
Ambient conditions Operating temperature Isolation class	-25 to +70° Celsius -13 to +158° Fahrenheit IP 20 (DIN 40 050)																					
Protocol specifications Supported Protocols Transmission speed Transmission speed detection Transmission speed switch Transmission speed detection time Data delay time Delay time jitter	DP-V0, DP- V1, DP-V2, FDL, MPI, FMS, PROFIsafe, PROFIdrive and any other FDL based protocol. 9.6 kbps to 12 Mbps (including 45.45 kbps) Auto detect (default) or selectable with rotary switch For position 1..D on B2+RD: Diagnostics Device ON 0 = Normal repeating (Auto detect, diag off) (default) 1 = 9.6 kbps 2 = 19.2 kbps 3 = 45.45 kbps 4 = 93.75 kbps 5 = 187.5 kbps 6 = 500 kbps 7 = 1500 kbps 8 = 3000 kbps 9 = 6000 kbps A = 12000 kbps B = Robust repeating (auto baudrate detect) C = Robust repeating, auto baudrate detect, redundancy on channel 4 and 5 D = Normal repeating (auto baudrate detect) E .. F = Same as 0 < 10 s (if it is set to auto detect) <table style="width: 100%; border-collapse: collapse;"> <thead> <tr> <th style="text-align: left;">At baudrate:</th> <th style="text-align: left;">Normal mode:</th> <th style="text-align: left;">Robust mode:</th> </tr> </thead> <tbody> <tr> <td>9.6 - 93.75 kbps</td> <td>≤1.7 Tbit</td> <td>≤13.25 Tbit</td> </tr> <tr> <td>187.5 - 500 kbps</td> <td>≤1.8 Tbit</td> <td>≤13.30 Tbit</td> </tr> <tr> <td>1.5 Mbps</td> <td>≤1.9 Tbit</td> <td>≤13.40 Tbit</td> </tr> <tr> <td>3 Mbps</td> <td>≤2.2 Tbit</td> <td>≤13.60 Tbit</td> </tr> <tr> <td>6 Mbps</td> <td>≤3.0 Tbit</td> <td>≤14.00 Tbit</td> </tr> <tr> <td>12 Mbps</td> <td>≤4.0 Tbit</td> <td>≤15.00 Tbit</td> </tr> </tbody> </table> Max. ¼ bit time	At baudrate:	Normal mode:	Robust mode:	9.6 - 93.75 kbps	≤1.7 Tbit	≤13.25 Tbit	187.5 - 500 kbps	≤1.8 Tbit	≤13.30 Tbit	1.5 Mbps	≤1.9 Tbit	≤13.40 Tbit	3 Mbps	≤2.2 Tbit	≤13.60 Tbit	6 Mbps	≤3.0 Tbit	≤14.00 Tbit	12 Mbps	≤4.0 Tbit	≤15.00 Tbit
At baudrate:	Normal mode:	Robust mode:																				
9.6 - 93.75 kbps	≤1.7 Tbit	≤13.25 Tbit																				
187.5 - 500 kbps	≤1.8 Tbit	≤13.30 Tbit																				
1.5 Mbps	≤1.9 Tbit	≤13.40 Tbit																				
3 Mbps	≤2.2 Tbit	≤13.60 Tbit																				
6 Mbps	≤3.0 Tbit	≤14.00 Tbit																				
12 Mbps	≤4.0 Tbit	≤15.00 Tbit																				
PROFIBUS Diagnostics Device specifications (only for B2+RD) Supported protocol Ident Number GSD filename Bus address Transmission speed Transmission speed detection Maximum transferrable data	DP-V0 6971 PROC6971.gsd 0-126 (software address only, set by software) 9.6 kbps .. 12 Mbps (including 45.45 kbps) Auto Detect 85 bytes input and 5 bytes output																					

Technical Data ProfiHub B2+	
PROFIBUS cable specifications	
Cable lengths	1200 m at 9.6 kbps to 93.75 kbps 1000 m at 187.5 kbps 400 m at 500 kbps 200 m at 1.5 Mbps 100 m at 3 Mbps to 12 Mbps
Cable thickness	10 mm (when the ground rail is used)
Wire diameter	< 2.5 mm ²
Wire type	Stranded or Solid core
Number of devices	Maximum 31 per Channel (including ProfiHubs, OLMs, Laptops/PCs, etc)
Termination	Integrated and switchable. Powered according to IEC 61158 (390/220/390 Ohms) - All Channels (default on) - Main-Channel (default off)
Cascading depth	No limits
Redundancy	Yes
Power supply specifications	
Power supply voltage	9 to 31 VDC
Redundant power supply	Yes
Current consumption	130 mA at 24 V power supply (all Channels fully loaded) Max. 4.1 W
Reverse polarity protection	Yes
Cable thickness	10 mm (when the ground rail is used)
Wire diameter	< 2.5 mm ²
Alarm contact	
Voltage	Max. 24 VDC
Current	0.5 A

5. Sales offices and distributors

HEADQUARTERS

PROCENTEC
Klopperman 16
2292 JD WATERINGEN
Netherlands

T: +31-(0)174-671800
F: +31-(0)174-671801
E: info@procentec.com
I: www.procentec.com

ARGENTINA

eFALCOM
Alcorta 2411
B1744 - Moreno
Buenos Aires
Argentina

T: +54 237 46 31 151
F: +54 237 46 31 150
E: santiago.falcomer@efalcom.com
I: www.efalcom.com.ar

AUSTRALIA

IS Systems Pty Limited
14 Laverick Ave.,
Tomago
NSW, Australia, 2322

T: +61 2 4964 8548
F: +61 2 4964 8877
E: fritz.woller@issystems.com.au
I: www.issystems.com.au

Pentair Flow Control Pacific
1 Percival Road
Smithfield
NSW, Australia, 2164

T: +61 2 4448 0466
F: +61 2 4423 3232
E: sharee.hazell@pentair.com.au
I: www.profibuscentre.com.au

BELGIUM and LUXEMBOURG

Bintz Technics N.V.
Brixtonlaan 23
B-1930 Zaventem
Belgium

T: +32 2 720 49 16
F: +32 2 720 37 50
E: bloemen@bintz.be
I: www.bintz.be

BRAZIL

Westcon Instrument. Indl Ltda
Rual Alvaro Rodrigues, 257
São Paulo – SP
Brazil - CEP 04582-000

T: +55 11 5561-7488
F: +55 11 5093-2592
E: paolo@wii.com.br
I: www.wii.com.br

CANADA

Streamline Process Management Inc.
#3, 4351 – 104 Ave SE
Calgary, Alberta T2C 5C6
Canada

T: +1 403 225 1986
F: +1 587 585 2828
E: admin@streamlinepm.com
I: www.streamlinepm.com

CHILE

RP Ingenieria Limitada
Tucapel 92 oficina 52
Concepción
Chile

T: +56-(0)41-2469350
F: +56-(0)41-2522592
E: rodrigopinto@rpingeneria.cl
I: www.rpingeneria.cl

CHINA

PROCENTEC Beijing
Room E-1115 WangJingYuan YouLeHui
ChaoYang
Beijing
China

T: +86(10)84766911 or 84787311
F: +86(10)84766722
E: info@procentec.net
I: www.procentec.net

CZECH REPUBLIC

FOXON s.r.o.
Polní 367
460 01 Liberec 12
Czech Republic

T: +420 484 845 555
F: +420 484 845 556
E: foxon@foxon.cz
I: www.foxon.cz

DENMARK

ProSaiCon
Jernbanegade 23B
DK 4000 Roskilde
Denmark

T: +45 70 20 52 01
F: +45 70 20 52 02
E: hfj@prosaicon.dk
I: www.prosaicon.dk

EGYPT

Mas Trading
37, 105 Street
Al-Etihad Square
Egypt

T: +2 02 2524 2842
F: +2 02 2524 2843
E: aya.elshafei@masautomation.com
I: www.masautomation.com

ESTONIA

Saksa Automaatika OU
Peterburi Tee 49
Tallinn
EE-11415 Estonia

T: +372 605 2526
F: +372 605 2524
E: info@saksa-automaatika.ee
I: www.saksa-automaatika.ee

FINLAND

Hantekno Oy
Kalliotie 2
04360 Tuusula
Finland

T: +358 40 8222 014
E: info@hantekno.com
I: www.hantekno.fi

FRANCE

AGILICOM
Bâtiment B
1, rue de la Briaudière
Z.A. La Châtaigneraie
37510 BALLAN-MIRE
France

T: +33 247 76 10 20
F: +33 247 37 95 54
E: jy.bois@agilicom.fr
I: www.agilicom.fr

GERMANY

PROCENTEC GmbH
Benzstrasse 15
D-76185 Karlsruhe
Germany

T: +49-(0)721 831 663-0
F: +49-(0)721 831 663-29
E: info@procentec.de
I: www.procentec.de

INDIA

UL Engineering Services & Software Pvt Ltd
Nirman Classic,
Katraj-Kondhwa Road,
Katraj, Pune-411046
India

T: +91-202 696 0050
F: +91-202 696 2079
E: dileep.miskin@ulepl.com
I: www.ulepl.com

IRELAND

PROFIBUS Ireland
Automation Research Centre
University of Limerick
National Technology Park, Plassey
Limerick
Ireland

T: +353-61-202107 or +35361240240
F: +353-61-202582
E: info@profibus.ie
I: www.profibus.ie

ISRAEL

Instrumentics Industrial Control
8 Hamlacha St.
New Industrial Zone
Netanya, 42170
Israel

T: +972-9-8357090
F: +972-9-8350619
E: info@instrumentics-ic.co.il
I: www.inst-ic.co.il

ITALY

PROCENTEC Italy
Via Branze n. 43/45
25123 Brescia
Italy

T: +39 030 200 8610
F: +39 030 238 0059
E: www.procentec.it
W: www.procentec.it

JAPAN

TJ Group
C/O Japanese PROFIBUS Organisation
West World Building 4F
3-1-6 Higashi-Gotanda,
Shinagawa-ku,
Tokyo, 141-0022
Japan

T: +81-3-6450-3739
F: +81-3-6450-3739
E: info@profibus.jp

KOREA

Hi-PRO Tech. Co., Ltd.
#2802, U-Tower, 1029
Youngduk-dong, Giheung-gu
Yongin-Si, Kyunggi-do,
446-908 Korea

T: +82 82-31-216-2640
F: +82 82-31-216-2644
E: chays@hiprotech.co.kr
I: www.profibus.co.kr

LEBANON

Industrial Technologies S.A.L. (ITEC)
Point Center, Boulevard Fouad Chehab
Sin El Fil
Beirut
Lebanon

T: +961 1 491161
F: +961 1 491162
E: sales@iteclb.com
I: www.iteclb.com

MEXICO

Grid Connect Inc.

T: +1 530-219-2565 (Spanish)
E: tomf@gridconnect.com
I: www.gridconnect.com

NETHERLANDS

PROCENTEC B.V.
Klopperman 16
2292 JD Wateringen
Netherlands

T: +31 (0)174 671800
F: +31 (0)174 671 801
E: info@procentec.com
I: www.procentec.com

NORWAY

AD Elektronikk AS
Boks 641
N-1401 SKI
Norway

T: +47 64 97 60 60
F: +47 64 97 60 70
E: kai@ade.no
I: www.ade.no

PERU

ControlWare
Jr. Los Silicios 5409
Los Olivos - L39
Peru

T: +51 1637 3735
F: +51 1528 0454
E: info@controlware.com.pe
I: www.controlware.com.pe

POLAND

INTEX Sp. z o.o.
ul. Portowa 4
44-102 Gliwice
Poland

T: +48 32 230 75 16
F: +48 32 230 75 17
E: intex@intex.com.pl
I: www.intex.com.pl

ROMANIA

S.C. SVT Electronics S.R.L.
Brăila 7
540331 Tg-Mure
Romania

T: +40 365 809 305
F: +40 365 809 305
E: sajgo.tibor@svt.ro
I: www.svt.ro

SAUDI ARABIA

ASM Process Automation
Al-Zahra Dist. – Attas st.
cross section with helmy Kutby St.
Villa no.25
Jeddah-21553
Saudi Arabia

T: +966 2 691 2741
F: +966 2 682 8943
E: info@asmestablishment.com
I: www.asmestablishment.com

SINGAPORE / SOUTH EAST ASIA

Allegro Electronics
236 Serangoon Avenue 3 07-98
Singapore 550236

T: +65 62878063
E: sales@allegro.com.sg
I: www.allegro.com.sg

Gissmatic Automatisierung Pte Ltd
318 Tanglin Road 01-34
Singapore 247979

T: +65 900 912 76
E: sales@gissmatic.com
I: www.gissmatic.com

SLOVAKIA

ControlSystem s.r.o.
Stúrova 4
977 01 BREZNO
Slovakia

T: +421 486115900
F: +421 486111891
E: jan.snopko@controlsystem.sk
E: jan.snopko@controlsystem.sk

SOUTH AFRICA

IDX ONLINE CC
1 Weaver Street
Fourways
Johannesburg
South Africa - 2191

T: +27(11) 548 9960
F: +27(11) 465-8890
E: sales@idxonline.com
I: www.idxonline.com

SPAIN

LOGITEK, S.A
Ctra. de Sant Cugat, 63 Esc. B Planta 1ª
Rubí (BARCELONA), 08191
Spain

T: +34 93 588 6767
E: xavier.cardena@logitek.es
I: www.logitek.es

SWEDEN

P&L Nordic AB
Box 252
S-281 23 Hässleholm
Sweden

T: +46 451 74 44 00
F: +46 451 89 833
E: hans.maunsbach@pol.se
I: www.pol.se/profibus

SWITZERLAND

**Berner Fachhochschule
PROFIBUS Kompetenzzentrum**
Jlcoweg 1
CH-3400 Burgdorf
Switzerland

T: +41 (0) 34 426 68 32
F: +41 (0) 34 426 68 13
E: max.felser@bfh.ch
I: www.profitrace.ch

TAIWAN

Full Data Technology
6F., No.200, Gangqian Rd.
Neihu District, Taipei City
114, Taiwan

T: +886-2-87519941/9097
F: +886-2-87519533
E: sales@fulldata.com.tw
I: www.fulldata.com.tw

TURKEY

Emikon Otomasyon
DES Sanayi sitesi 103 sokak
B-7 blok No:16 Yukari Dudullu / Umraniye
Istanbul 34776
Turkey

T: +90 216 420 8347
F: +90 216 420 8348
E: tolgaturunz@emikonotomasyon.com
I: www.emikonotomasyon.com

UNITED ARAB EMIRATES

Synergy Controls
907, IT Plaza Silicon Oasis :
Dubail
United Arab Emirates

T: +971 4 3262692
F: +971 4 3262693
E: sales@synergycontrols.ae

UNITED KINGDOM and N. Ireland

Verwer Training & Consultancy
5 Barclay Road
Poynton, Stockport
Cheshire SK12 1YY
United Kingdom

T: +44 (0)1625 871199
E: andy@verwertraining.com
I: www.verwertraining.com

Hi-Port Software
The Hub 2 Martin Close
Lee-on-Solent
Hampshire PO13 8LG
United Kingdom

T: +44 (0)8452 90 20 30
F: +44 (0)2392 552880
E: sales@hiport.co.uk
I: www.hiport.co.uk

iTech
Unit 1
Dukes Road
Troon
Ayrshire KA10 6QR
United Kingdom

T: +44 (0)1292 311 613
F: +44 (0)1292 311 578
E: sales@itech-troon.co.uk
I: www.itech-troon.co.uk

Parkelect Ltd.
84 Dargan Road
Belfast
BT3 9JU
N. Ireland

T: +44 2890 777743
F: +44 2890 777794
E: jgillan@parkelect.co.uk
I: www.parkelect.co.uk

UNITED STATES

Grid Connect Inc.
1630 W. Diehl Road
Naperville, Illinois 60563
USA

T: +1 630 245-1445
F: +1 630 245-1717
E: sales@gridconnect.com
I: www.gridconnect.com/procentec.html



VIETNAM

Bavitech Corporation
42 Truong Son Street
Ward 2, Tan Binh District
Ho Chi Minh City
Vietnam

T: +84-8-3547 0976
F: +84-8-3547 0977
E: hai.hoang@bavitech.com
I: www.bavitech.com

For the up to date list of the Sales Offices and Distributors see www.procentec.com/company/distributors/. If your country or region is not listed, please contact us. We are still searching for distributors who can cover complete areas or countries.

6. Order codes

Component	Order code	Remarks
 <p>ProfiHub B2+</p>	17210	ProfiHub B2+ With redundant channels With Alarm contact With redundant power input
 <p>ProfiHub B2+RD</p>	17210RD	ProfiHub B2+ with Diagnostics Device With redundant channels With Alarm contact With redundant power input

7. Glossary

Address	Unique number of a device connected to the network. With PROFIBUS this can be 0 to 126. 127 is a broadcast address.
Analyzer	Software tool to observe the protocol traffic. Combi-Analyzers can also inspect the signal quality. Other term: Bus Monitor. Example: ProfiTrace.
Backbone	The primary bus cable. Most of the time only the control systems, ProfiHubs and fiber optic couplers are connected to this cable. The field devices are connected behind the ProfiHubs and fiber optic couplers.
Bit Time (Tbit)	The bit time Tbit is the time, which elapses during the transmission of one bit. It depends on the baudrate and is calculated as follows $Tbit = 1 \text{ (bit)} / \text{baudrate (bps)}$. Examples: 12 Mbps --> Tbit = 83 ns 1.5 Mbps --> Tbit = 667 ns
Busparameters	Settings that define the timing behaviour on the bus. They are defined in the master. Examples: Tslot, MaxTSDR.
C	Capacitance.
DGND	Digital Ground.
DIN	German Institute for Standardization (www.din.de).
DP-V0	DP-V0 is the basic stage of the PROFIBUS DP communication protocol. DP-V0 devices (master and slaves) perform the following basic functionalities: <ul style="list-style-type: none">- Cyclic exchange of I/O data between controlling and slave devices- Device, Identifier (module) and Channel related Diagnosis- Parameterization of DP-slaves- Configuration of DP-slaves
DP-V1	DP-V1 is the first stage of extension of PROFIBUS DP after DP-V0. DP-V1 devices shall comply with the following features: <ul style="list-style-type: none">- Device related diagnosis is replaced by status and alarms.- The first three octets of the user parameterization data are now standardized- Optionally these devices may support:- Acyclic communication (MS1, MS2)- If alarms are used, MS1 shall be supported

DP-V2	<p>DP-V2 is the second stage of extension of PROFIBUS DP after DP-V1. DP-V2 devices shall comply with the following features:</p> <ul style="list-style-type: none"> - Data Exchange Broadcast (DxB) for slave to slave communication (publisher/subscriber principle). - Isochronous Mode (time tick synchronized operating slaves, e.g. drives) - Up- and/or download of Load Region Data (domains) - Clock Control (synchronization within slaves) and Time Stamping - Redundancy.
Electromagnetic Compatibility	<i>See EMC.</i>
EMC	<p>The extent to which an electric or electronic device will tolerate electrical interference from other equipment (immunity), and will interfere with other equipment. Within the European Community as well as in other countries it is regulated by law that electric and electronic components and equipment comply with basic standards such as IEC 61000-6-2 or IEC 61326 or corresponding individual product standards.</p>
Hub	<p>A Hub refreshes a signal and passes the information on to all nodes which are connected to the Hub. Data frames which were received on one port are transferred to all the other ports (chicken foot topology).</p>
MPI	<p>Multiple Protocol Interface. Protocol defined by Siemens which uses the layer 1 and 2 of PROFIBUS (FDL).</p>
PCB	Printed Circuit Board.
PROFIBUS DP	<p>Acronym for "PROFIBUS for Decentralized Peripherals". Specification of an open fieldbus system with the following characteristics:</p> <ul style="list-style-type: none"> - Polling master-slave-system (cyclic communications, MS0) - Flying masters with robin round token passing coordination (MM) - Connection based (MS1) and connectionless (MS2, MS3) acyclic communication between masters and slaves <p>Options (e.g.):</p> <ul style="list-style-type: none"> - Data exchange broadcast (DXB), i.e. slave to slaves communication - Isochronous mode of slaves - Clock synchronization - Redundancy <p>PROFIBUS DP is standardized within IEC 61158 and IEC 61784, communication profile families 3/1 and 3/2</p> <p>The term "PROFIBUS DP" also is a synonym for the RS485 based deployments within factory automation.</p>
Repeater	<p>Active physical layer device that receives and retransmits all signals over a different port to increase the distance and number of devices for which signals can be correctly transferred for a given medium.</p>
Spur line	<p>A cable attached to a bus segment with a T-connection . Spurs are not recommended with PROFIBUS DP. They are prohibited with 12 Mbps and PROFIsafe operations. German term is "Stichleitung".</p>

Stub line	See <i>Spur line</i> .
Tbit	See <i>Bit Time</i> .
Termination	A (powered) resistor network at both ends of a segment to prevent reflections (with PROFIBUS DP the termination must be powered).
Topology	In a communications network, the pattern of interconnection between network nodes; e.g. bus, ring, star configuration.
PI	PROFIBUS International. The International PROFIBUS Organization based in Karlsruhe.
PNO	PROFIBUS Nutzer Organization. The German PROFIBUS Organization based in Karlsruhe.
Drop cable	See <i>Spur line</i> .
Reflection	Part of the original signal that is transmitted back along the cable. It corrupts the original signal.

8. Revision History

Version 1.0

First release.

Version 2.0

Added chapter 'Diagnostics Device'

Textual changes in all chapters to adapt to B2+RD

Version 2.1.0

Textual changes

10. Other PROCENTEC products

IP 66 Compact PROFIBUS repeater

- Single channel PROFIBUS repeater
- Robust Repeating; reduces errors
- IP 66
- Transparent
- Max. 12 Mbps
- Auto baudrate detection
- Digital glitch filtering
- No limit in cascading
- On-board switchable termination
- Diagnostic LEDs
- M12 connector for measurements



Compact PROFIBUS Repeater

- Single channel PROFIBUS repeater
- Transparent
- Latest RS 485 technology
- Max. 12 Mbps
- Auto baudrate detection
- Redundant power supply
- Digital glitch filtering
- No limit in cascading
- Integrated switchable termination
- Diagnostic LEDs
- DB9 connector for measurements
- IP 20 with DIN-rail mounting

www.procentec.com/profihub/b1/en



11. About PROCENTEC

PROCENTEC is a specialist in PROFIBUS and PROFINET technology and develops products to optimize the production processes of end users. Our innovative solutions ensure that our customers successfully operate in the world of industrial automation and enjoy maximum results from their process.

PROCENTEC globally supplies all the components required to install a measurable and steerable network. We develop and produce all products in the Netherlands and they are exported through our worldwide distribution network. At PROCENTEC, we have a professional team of qualified support engineers who provide technical support on-site and online. Our professionals have more than 20 years of experience with PROFIBUS and PROFINET technology. They provide the necessary support to end users during implementation procedures, certification processes, audits and malfunctions. PROCENTEC also is the international accredited Competence and Training centre for PROFIBUS and PROFINET. We provide training courses that help employees using those techniques optimally for their business objectives.

Products

- ProfiTrace
- ComBricks
- ProfiHub
- PROFINET tools
- Cables and connectors

Training

- PROFIBUS training courses
- PROFINET training courses
- Product training courses

Services

- On-site & Online Support
- Network Audit
- Network Certification
- Consultancy



12. Certificates

certificatie

QualityMasters hereby declares that

Procentec B.V.
Wateringen

M

has a management system that meets the requirements of the standard

NEN-EN-ISO 9001:2008

for the scope

Providing training courses, technical support, product development and the exploitation of the test laboratory.

Date of original approval	10-02-2003
Date of issue	10-04-2013
Valid until	10-02-2016
Certificate number	NL 6313uk

On behalf of Stichting QualityMasters,



N.B. The failure to meet the conditions as set forth in the certification agreement, or non-compliance with the given standard and/or guidelines, may lead to the suspension or cancellation of the certificate.
This certificate remains the property of Stichting QualityMasters, Nieuwland Parc 157, 3351 LJ Papendrecht.



**Certificate
for a PI Competence Center**

PI confirms that

**PROCENTEC
Elmer Vis
Klopperman 16
2292 JD WATERINGEN
NETHERLANDS**

is a fully accredited PI Competence Center for
PROFINET basic
PROFIsafe.

This certificate is granted according to the Quality of Services Agreement for
PI Competence Centers and is valid until December 31, 2017.



(Official in Charge)

Chairmen of PI



(Karsten Schneider, Chairman)



(Michael J. Bryant, Deputy Chairman)



**PROFI[®]
NET**

Certificate for a PI Training Center

PI confirms that

PROCENTEC
Klopperman 16
2292 JD WATERINGEN
THE NETHERLANDS

is a fully accredited PI Training Center for
PROFIBUS Installers, Engineers & PA Engineers.

Instructors:

Dennis van Booma
Dave van Cappelle
Joost van der Nat
Edward Dumay

Elmer Vis
Fedor Meyer
Sander Vermin

Mark de Brabander
Paulo Silva
Alois Schenkeveld

This certificate is granted according to the Quality of Services Agreement for
PI Training Centers and is valid until December 31, 2016.



(Official in Charge)

Chairmen of PI



(Karsten Schneider, Chairman)



(Michael J. Bryant, Deputy Chairman)



Certificate

Authorization as PI Test Laboratory for PROFIBUS

PROFIBUS Nutzerorganisation e.V. accepts
PROCENTEC
Klopperman 16
2292 JD Wieringen
The Netherlands

as authorized PI Test Laboratory for:

PROFIBUS Slave Devices PA Profile Devices

The authorization is based on the assessment dated February 19, 2015, and the related assessment report.

The execution of the tests aimed in the PROFIBUS certification shall be conform to the PROFIBUS Standard and the valid guidelines.

This authorization is valid until December 31, 2016.



(Official in Charge)

Board of PROFIBUS Nutzerorganisation e. V.

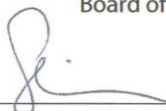

(K. Schneider)

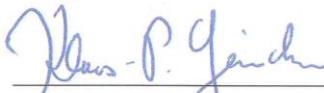

(K.-P. Lindner)





PROCENTEC BV
Klopperman 16
2292 JD Wateringen
The Netherlands

T: +31 (0)174 671 800

F: +31 (0)174 671 801

E: support@procentec.com

W: www.procentec.com

